

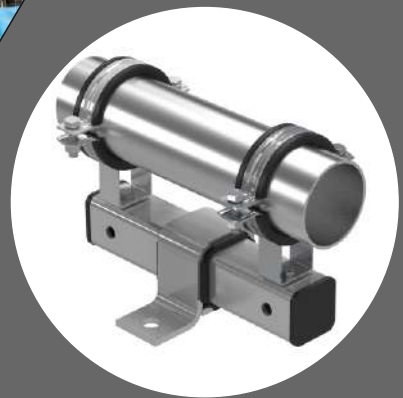

ЕНЕРДЖИ ГРУП ООД

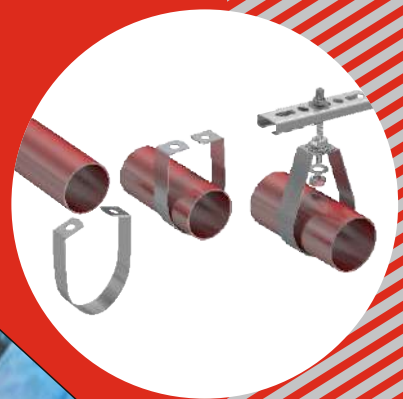

Скоби за тръби



**www.abelectric.bg
www.abenergygroup.bg**



ЕНЕРДЖИ ГРУП ООД



Системи за фиксиране на тръби

Pipe Clamp with nut - Скоба за тръба с гайка					
With Rubber  SK	Without Rubber  SKL	With Rubber (Set)  SKS	Without Rubber (Set)  SKSL		
Pipe Clamp with Combi Nut - Скоба за тръба с комбинирана гайка					
With Rubber  KS	Without Rubber  KSL	With Rubber (Set)  KSS	Without Rubber (Set)  KSLs		
Pipe Clamps With Triphone - Скоби за тръби с трифон					
With Rubber  TF	Without Rubber  TFL	With Rubber  TU	Without Rubber  TUL	Without Rubber(Set)  TFS	Without Rubber(Set)  TFLS
Heavy Duty Pipe Clamp with Head - Тежка работа - скоба за тръба с глава					
With Rubber  AK	Without Rubber  AKL	With Rubber  AS	Without Rubber  ASL	With Rubber(Set)  ACS	Without Rubber(Set)  ACSL
Sprinkler Pipe Clamps - Скоби за спринклерни тръби				Pvc Pipe Clamps - Скоби за PVC тръби	
Standard  SPR	Long  SPRU	With Rivet Nut  SPRS	 PBK		
Ventilation Pipe Clamps - Скоби за вентилационни тръби					
With Rubber  HS	Without Rubber  HSL	With Combi Nut  HKS	Combi Nut Without Rubber  HKSL	With Rubber  HC	Without Rubber  HSL
Sliding Hinge - Плъзгаща се панта		Collector Clamp - Колекторна скоба		U Bolt Pipe Clamp - Скоба за тръба с U болт	
 KM		 KOL		 UB	
Insulation Support - Изолационна опора					
 PIT					
Profiles & Channels - Профили и канали					
 CL 2718	 CL 2830	 C 2141	 C 4141	 CL 27	 CL 28
 C 21		 C 41			
Accessories - Аксесоари					
 UT4 - UT5	 UT6 - UT7	 UT8	 CLE	 CLB	 NTP-NTN

Pipe Clamps



ЕНЕРДЖИ ГРУП ООД

Pipe Clamp With Nut

Скоба за тръба с гайка



Application

Used with pvc, pe, pp, cast iron, steel and copper pipes.

Mounting Example

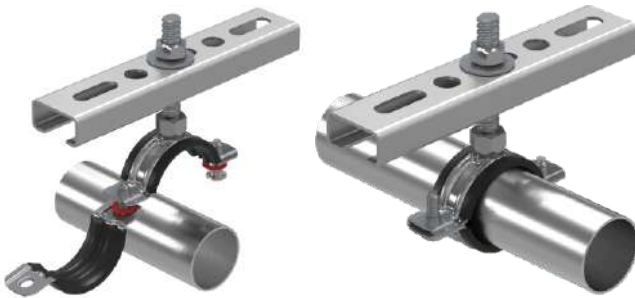

SK

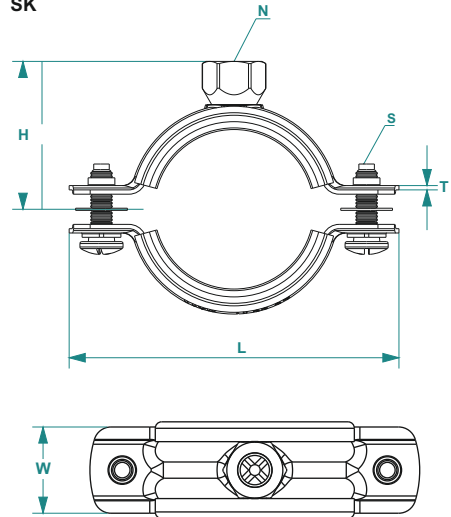

Clamping range with rubber

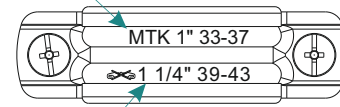

Clamping range without rubber

Material
Steel
Standard Finish
Zinc Plated
Hardness of Rubber Lining
55 \pm 5 Shore A/
Standard TPE, on request EPDM
Standard TPE,
Temperature Resistance
-50 $^{\circ}$ C / +110 $^{\circ}$ C

SK

CODE	SIZE	CLAMPING RANGE (mm)	LENGTH (L) (mm)	HEIGHT (H) (mm)	SHEET (TxW) (mm)	SCREW (S) (metric)	NUT (N) (mm)	BREAKING LOAD (kN)	RECOMMENDED LOAD (kN)	QUANTITY PER BOX (Pcs)	WEIGHT PER BOX AVARAGE KG)
SK 006	1/8"	9 - 12	52,1	22,5	1x20	M5	M8	3,9	1,3	300	10,80
SK 008	1/4"	13 - 20	54,5	24	1x20	M5	M8	3,9	1,3	250	9,50
SK 010	3/8"	17 - 23	58,5	26	1x20	M5	M8	3,9	1,3	250	10,25
SK 015	1/2"	20 - 25	62,5	28	1x20	M5	M8	3,9	1,3	200	8,60
SK 020	3/4"	25 - 30	68,5	31	1x20	M5	M8	3,9	1,3	150	7,05
SK 025	1"	32 - 37	76	34,5	1x20	M5	M8	3,9	1,3	150	7,95
SK 032	1 1/4"	40 - 46	91,5	39	1,2x20	M5	M8	4,8	1,6	100	6,80
SK 040	1 1/2"	48 - 53	99	42,5	1,2x20	M5	M8	4,8	1,6	75	5,63
SK 047	53-59	53 - 59	105	45,5	1,2x20	M5	M8	4,8	1,6	75	6,00
SK 050	2"	60 - 66	112	49	1,2x20	M5	M8	4,8	1,6	50	4,35
SK 060	67-77	67 - 77	126	56	1,5x25	M6	M10	6,9	2,3	40	6,08
SK 065	2 1/2"	75 - 84	134	60	1,5x25	M6	M10	6,9	2,3	40	6,36
SK 075	83-93	83 - 93	142	64	1,5x25	M6	M10	6,9	2,3	40	6,80
SK 080	3"	87 - 96	145	65,5	1,5x25	M6	M10	6,9	2,3	40	6,96
SK 085	94-104	94 - 104	153	69,5	1,5x25	M6	M10	6,9	2,3	30	5,79
SK 095	102-111	102 - 111	161	73,5	1,5x25	M6	M10	6,9	2,3	40	7,76
SK 100	4"	109 - 119	170	78	1,5x25	M6	M10	6,9	2,3	30	6,15
SK 110	122-135	122 - 135	184	84,5	2x25	M6	M10	7,8	2,6	30	8,07
SK 120	128-139	128 - 139	190	87,5	2x25	M6	M10	7,8	2,6	30	8,43
SK 125	5"	135 - 148	197	91	2x25	M6	M10	7,8	2,6	25	7,38
SK 140	151-164	151 - 164	213	99	2x25	M6	M10	7,8	2,6	25	8,00
SK 150	6"	158 - 170	222	103,5	2x25	M6	M10	7,8	2,6	20	6,82
SK 180	194-205	194 - 205	257	121	2x25	M6	M12	7,8	2,6	15	5,93
SK 200	8"	214 - 224	272	130	2x25	M6	M12	7,8	2,6	15	6,29

Pipe Clamps



ЕНЕРДЖИ ГРУП ООД

Pipe Clamp Without Rubber

Скоба за тръба без гума



Application / Uygulama

Used with pvc, pe, pp, cast iron, steel and copper pipes.

Mounting Example

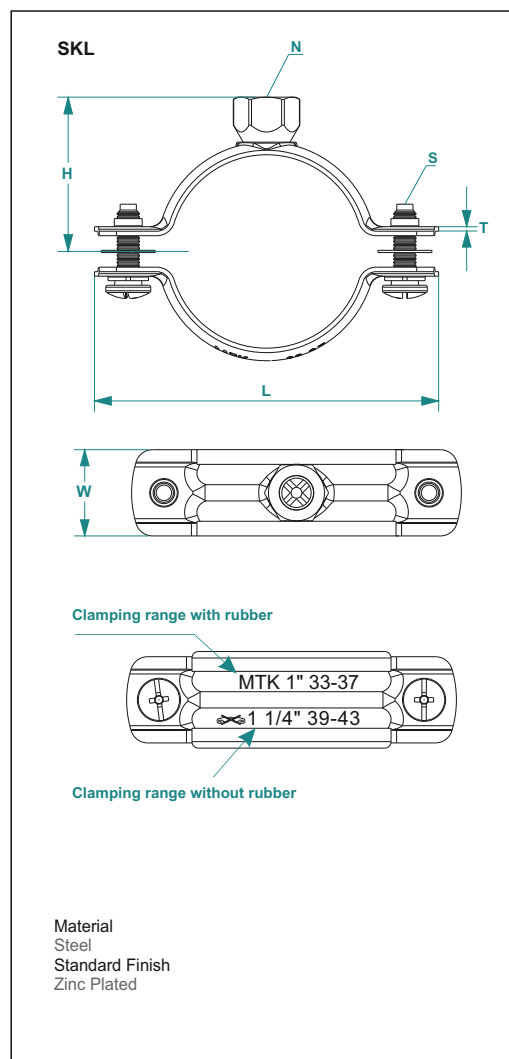

SKL

CODE	SIZE	CLAMPING RANGE	LENGTH	HEIGHT	SHEET	SCREW	NUT	BREAKING	RECOMMENDED	QUANTITY	WEIGHT PER BOX
		(mm)	(L) (mm)	(H) (mm)	(TxW) (mm)	(S) (metric)	(N) (mm)	LOAD (kN)	LOAD (kN)	PER BOX (Pcs)	AVARAGE KG
SKL 010	3/8"	15 - 20	52,1	22,5	1x20	M5	M8	3,9	1,3	300	9,90
SKL 015	1/2"	19 - 23	54,5	24	1x20	M5	M8	3,9	1,3	250	8,50
SKL 017	23-28	23 - 28	58,5	26	1x20	M5	M8	3,9	1,3	150	5,55
SKL 020	3/4"	25 - 30	62,5	28	1x20	M5	M8	3,9	1,3	200	7,60
SKL 025	1"	31 - 35	68,5	31	1x20	M5	M8	3,9	1,3	200	8,00
SKL 032	1 1/4"	38 - 43	76	34,5	1x20	M5	M8	3,9	1,3	150	6,60
SKL 040	1 1/2"	45 - 51	91,5	39	1,2x20	M5	M8	4,8	1,6	100	5,80
SKL 047	54-58	54 - 58	99	42,5	1,2x20	M5	M8	4,8	1,6	100	6,30
SKL 050	2"	60 - 65	105	45,5	1,2x20	M5	M8	4,8	1,6	100	6,60
SKL 060	67-71	67 - 71	112	49	1,2x20	M5	M8	4,8	1,6	75	5,70
SKL 065	2 1/2"	74 - 82	126	56	1,5x25	M6	M10	6,9	2,3	50	6,35
SKL 075	82-89	82 - 89	134	60	1,5x25	M6	M10	6,9	2,3	50	6,65
SKL 080	3"	91 - 98	142	64	1,5x25	M6	M10	6,9	2,3	50	6,95
SKL 085	93-101	93 - 101	145	65,5	1,5x25	M6	M10	6,9	2,3	50	7,20
SKL 095	102-109	102 - 109	153	69,5	1,5x25	M6	M10	6,9	2,3	50	7,85
SKL 100	4"	109 - 117	161	73,5	1,5x25	M6	M10	6,9	2,3	50	7,95
SKL 110	116-125	116 - 125	170	78	1,5x25	M6	M10	6,9	2,3	50	8,25
SKL 120	129-141	129 - 141	184	84,5	2x25	M6	M10	7,8	2,6	50	11,20
SKL 125	5"	136 - 146	190	87,5	2x25	M6	M10	7,8	2,6	40	9,40
SKL 140	142-154	142 - 154	197	91	2x25	M6	M10	7,8	2,6	25	6,23
SKL 150	6"	158 - 169	213	99	2x25	M6	M10	7,8	2,6	30	7,98
SKL 180	166-177	166 - 177	222	103,5	2x25	M6	M10	7,8	2,6	20	5,76
SKL 190	201-212	201 - 212	257	121	2x25	M6	M12	7,8	2,6	15	4,94
SKL 200	8"	219 - 229	272	130	2x25	M6	M12	7,8	2,6	15	5,24

Pipe Clamps



ЕНЕРДЖИ ГРУП ООД

Pipe Clamp With Nut (Set)

Скоба за тръба с гайка (Комплект)



SKS clamp includes hanger bolt and plastic dowel

Application

Used with pvc, pe, pp, cast iron, steel and copper pipes.

Package View & Mounting Example



SKS

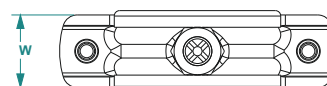
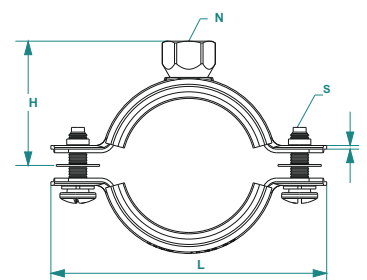

Clamping range with rubber

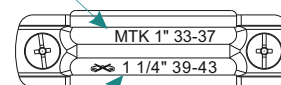

Clamping range without rubber

Hanger bolt

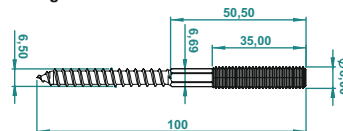

Dowel



Material

Steel

Standard Finish

Zinc Plated

Hardness of Rubber Lining

55 \pm 5 Shore A

Isolation Rubber

Standard TPE, on request EPDM

Temperature Resistance / Сıcaklık Dayanımı

-50 $^{\circ}$ C / +110 $^{\circ}$ C

SKS

CODE	SIZE	CLAMPING RANGE (mm)	LENGTH (L) (mm)	HEIGHT (H) (mm)	SHEET (TxW) (mm)	SCREW (S) (metric)	NUT (N) (mm)	HANGER BOLT (A) (metric)	DOWEL (D) (mm)	BREAKING LOAD (kN)	RECOMMENDED LOAD (kN)	QUANTITY PER BOX (Pcs)	WEIGHT PER BOX AVERAGE KG)
SKS 006	1/8"	9 - 12	52,1	22,5	1x20	M5	M8	M8x80	10	3,9	1,3	150	8,81
SKS 008	1/4"	13 - 20	54,5	24	1x20	M5	M8	M8x80	10	3,9	1,3	120	7,28
SKS 010	3/8"	17 - 23	58,5	26	1x20	M5	M8	M8x80	10	3,9	1,3	100	6,43
SKS 015	1/2"	20 - 25	62,5	28	1x20	M5	M8	M8x80	10	3,9	1,3	100	6,64
SKS 020	3/4"	25 - 30	68,5	31	1x20	M5	M8	M8x80	10	3,9	1,3	100	7,06
SKS 025	1"	32 - 37	76	34,5	1x20	M5	M8	M8x80	10	3,9	1,3	80	6,13
SKS 032	1 1/4"	40 - 46	91,5	39	1,2x20	M5	M8	M8x80	10	4,8	1,6	60	5,54
SKS 040	1 1/2"	48 - 53	99	42,5	1,2x20	M5	M8	M8x80	10	4,8	1,6	50	5,00
SKS 047	53-59	53 - 59	105	45,5	1,2x20	M5	M8	M8x80	10	4,8	1,6	50	5,25
SKS 050	2"	60 - 66	112	49	1,2x20	M5	M8	M8x80	10	4,8	1,6	50	5,52
SKS 060	67-77	67 - 77	126	56	1,5x25	M6	M10	M10x100	12	6,9	2,3	40	7,75
SKS 065	2 1/2"	75 - 84	134	60	1,5x25	M6	M10	M10x100	12	6,9	2,3	40	8,05
SKS 075	83-93	83 - 93	142	64	1,5x25	M6	M10	M10x100	12	6,9	2,3	40	8,46
SKS 080	3"	87 - 96	145	65,5	1,5x25	M6	M10	M10x100	12	6,9	2,3	40	8,65
SKS 085	94-104	94 - 104	153	69,5	1,5x25	M6	M10	M10x100	12	6,9	2,3	30	7,04
SKS 095	102-111	102 - 111	161	73,5	1,5x25	M6	M10	M10x100	12	6,9	2,3	30	7,13
SKS 100	4"	109 - 119	170	78	1,5x25	M6	M10	M10x100	12	6,9	2,3	30	7,39
SKS 110	122-135	122 - 135	184	84,5	2x25	M6	M10	M10x100	12	7,8	2,6	30	9,30
SKS 120	128-139	128 - 139	190	87,5	2x25	M6	M10	M10x100	12	7,8	2,6	25	8,00
SKS 125	5"	135 - 148	197	91	2x25	M6	M10	M10x100	12	7,8	2,6	20	6,73
SKS 140	151-164	151 - 164	213	99	2x25	M6	M10	M10x100	12	7,8	2,6	20	7,28
SKS 150	6"	158 - 170	222	103,5	2x25	M6	M10	M10x100	12	7,8	2,6	20	7,63
SKS 180	194-205	194 - 205	257	121	2x25	M6	M12	M12x100	14	7,8	2,6	10	4,66
SKS 200	8"	214 - 224	272	130	2x25	M6	M12	M12x100	14	7,8	2,6	10	4,90

Pipe Clamps



ЕНЕРДЖИ ГРУП ООД

Pipe Clamp Without Rubber (Set)

Скоба за тръба без гума (Комплект)



SKS iclamp includes hanger bolt and plastic dowel

Application

Used with pvc, pe, pp, cast iron, steel and copper pipes.

Package View & Mounting Example

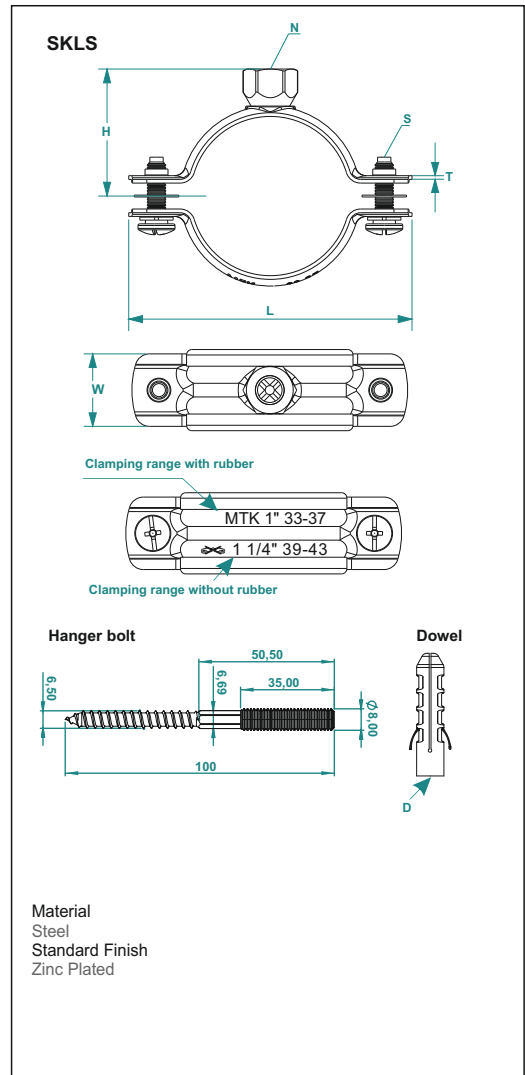

SKLS

CODE	SIZE	CLAMPING RANGE (mm)	LENGTH (L) (mm)	HEIGHT (H) (mm)	SHEET (TxW) (mm)	SCREW (S) (metric)	NUT (N) (mm)	HANGER BOLT (A) (metric)	DOWEL (D) (mm)	BREAKING LOAD (kN)	RECOMMENDED LOAD (kN)	QUANTITY PER BOX (Pcs)	WEIGHT PER BOX AVERAGE KG
SKLS 010	3/8"	15 - 20	52,1	22,5	1x20	M5	M8	M8x80	10	3,9	1,3	150	7,65
SKLS 015	1/2"	19 - 23	54,5	24	1x20	M5	M8	M8x80	10	3,9	1,3	120	6,24
SKLS 017	23-28	23 - 28	58,5	26	1x20	M5	M8	M8x80	10	3,9	1,3	100	5,50
SKLS 020	3/4"	25 - 30	62,5	28	1x20	M5	M8	M8x80	10	3,9	1,3	100	5,70
SKLS 025	1"	31 - 35	68,5	31	1x20	M5	M8	M8x80	10	3,9	1,3	100	5,90
SKLS 032	1 1/4"	38 - 43	76	34,5	1x20	M5	M8	M8x80	10	3,9	1,3	80	5,04
SKLS 040	1 1/2"	45 - 51	91,5	39	1,2x20	M5	M8	M8x80	10	4,8	1,6	60	4,56
SKLS 047	54-58	54 - 58	99	42,5	1,2x20	M5	M8	M8x80	10	4,8	1,6	50	4,05
SKLS 050	2"	60 - 65	105	45,5	1,2x20	M5	M8	M8x80	10	4,8	1,6	50	4,20
SKLS 060	67-71	67 - 71	112	49	1,2x20	M5	M8	M8x80	10	4,8	1,6	50	4,80
SKLS 065	2 1/2"	74 - 82	126	56	1,5x25	M6	M10	M10x100	12	6,9	2,3	40	6,56
SKLS 075	82-89	82 - 89	134	60	1,5x25	M6	M10	M10x100	12	6,9	2,3	40	6,80
SKLS 080	3"	91 - 98	142	64	1,5x25	M6	M10	M10x100	12	6,9	2,3	40	7,08
SKLS 085	93-101	93 - 101	145	65,5	1,5x25	M6	M10	M10x100	12	6,9	2,3	40	7,24
SKLS 095	102-109	102 - 109	153	69,5	1,5x25	M6	M10	M10x100	12	6,9	2,3	30	5,88
SKLS 100	4"	109 - 117	161	73,5	1,5x25	M6	M10	M10x100	12	6,9	2,3	30	5,88
SKLS 110	116-125	116 - 125	170	78	1,5x25	M6	M10	M10x100	12	6,9	2,3	30	6,15
SKLS 120	129-141	129 - 141	184	84,5	2x25	M6	M10	M10x100	12	7,8	2,6	30	7,89
SKLS 125	5"	136 - 146	190	87,5	2x25	M6	M10	M10x100	12	7,8	2,6	25	6,83
SKLS 140	142-154	142 - 154	197	91	2x25	M6	M10	M10x100	12	7,8	2,6	20	5,70
SKLS 150	6"	158 - 169	213	99	2x25	M6	M10	M10x100	12	7,8	2,6	20	6,08
SKLS 180	166-177	166 - 177	222	103,5	2x25	M6	M10	M10x100	12	7,8	2,6	20	6,48
SKLS 190	201-212	201 - 212	257	121	2x25	M6	M12	M12x100	14	7,8	2,6	10	3,83
SKLS 200	8"	219 - 229	272	130	2x25	M6	M12	M12x100	14	7,8	2,6	10	4,03

Pipe Clamp With Combi Nut

Скоба за тръба с комбинирана гайка



Combi Nut
(Section)

Application

Used with pvc, pe, pp, cast iron, steel and copper pipes.

Mounting Example



KS

Clamping range with rubber

Clamping range without rubber

Material
Steel
Standard Finish
Zinc Plated
Hardness of Rubber Lining
55±5 Shore A
Isolation Rubber
Standard TPE, on request EPDM
Temperature Resistance
-50°C / +110°C

KS

CODE	SIZE	CLAMPING RANGE (mm)	LENGTH (L) (mm)	HEIGHT (H) (mm)	SHEET (TxW) (mm)	SCREW (S) (metric)	NUT (N) (mm)	BREAKING LOAD (kN)	RECOMMENDED LOAD (kN)	QUANTITY PER BOX (Pcs)	WEIGHT PER BOX (AVERAGE KG)
KS 006	1/8"	9 - 12	52,1	30,5	1x20	M5	M8 / M10	3,9	1,3	250	10,75
KS 008	1/4"	13 - 20	54,5	32	1x20	M5	M8 / M10	3,9	1,3	250	11,25
KS 010	3/8"	17 - 23	58,5	34	1x20	M5	M8 / M10	3,9	1,3	250	12,00
KS 015	1/2"	20 - 25	62,5	36	1x20	M5	M8 / M10	3,9	1,3	200	10,00
KS 020	3/4"	25 - 30	68,5	39	1x20	M5	M8 / M10	3,9	1,3	150	8,10
KS 025	1"	32 - 37	76	42,5	1x20	M5	M8 / M10	3,9	1,3	150	9,00
KS 032	1 1/4"	40 - 46	91,5	47	1,2x20	M5	M8 / M10	4,8	1,6	100	7,50
KS 040	1 1/2"	48 - 53	99	50,5	1,2x20	M5	M8 / M10	4,8	1,6	75	6,15
KS 047	53-59	53 - 59	105	53,5	1,2x20	M5	M8 / M10	4,8	1,6	75	6,53
KS 050	2"	60 - 66	112	57	1,2x20	M5	M8 / M10	4,8	1,6	50	4,70
KS 060	67-77	67 - 77	126	62	1,5x25	M6	M8 / M10	6,9	2,3	40	6,04
KS 065	2 1/2"	75 - 84	134	66	1,5x25	M6	M8 / M10	6,9	2,3	40	6,36
KS 075	83-93	83 - 93	142	70	1,5x25	M6	M8 / M10	6,9	2,3	40	6,76
KS 080	3"	87 - 96	145	71,5	1,5x25	M6	M8 / M10	6,9	2,3	40	6,96
KS 085	94-104	94 - 104	153	75,5	1,5x25	M6	M8 / M10	6,9	2,3	30	5,76
KS 095	102-111	102 - 111	161	79,5	1,5x25	M6	M8 / M10	6,9	2,3	40	7,72
KS 100	4"	109 - 119	170	84	1,5x25	M6	M8 / M10	6,9	2,3	30	6,12
KS 110	122-135	122 - 135	184	90,5	2x25	M6	M8 / M10	7,8	2,6	30	8,04
KS 120	128-139	128 - 139	190	93,5	2x25	M6	M8 / M10	7,8	2,6	30	8,40
KS 125	5"	135 - 148	197	97	2x25	M6	M8 / M10	7,8	2,6	25	7,38
KS 140	151-164	151 - 164	213	105	2x25	M6	M8 / M10	7,8	2,6	25	8,00
KS 150	6"	158 - 170	222	109,5	2x25	M6	M8 / M10	7,8	2,6	20	6,80
KS 180	194-205	194 - 205	257	127	2x25	M6	M8 / M10	7,8	2,6	15	5,87
KS 200	8"	214 - 224	272	136	2x25	M6	M8 / M10	7,8	2,6	15	6,23

Pipe Clamp With Combi Nut Without Rubber

Скоба за тръба с комбинирана гайка без гума



Combi Nut
(Section)

Application

Used with pvc, pe, pp, cast iron, steel and copper pipes.

Mounting Example

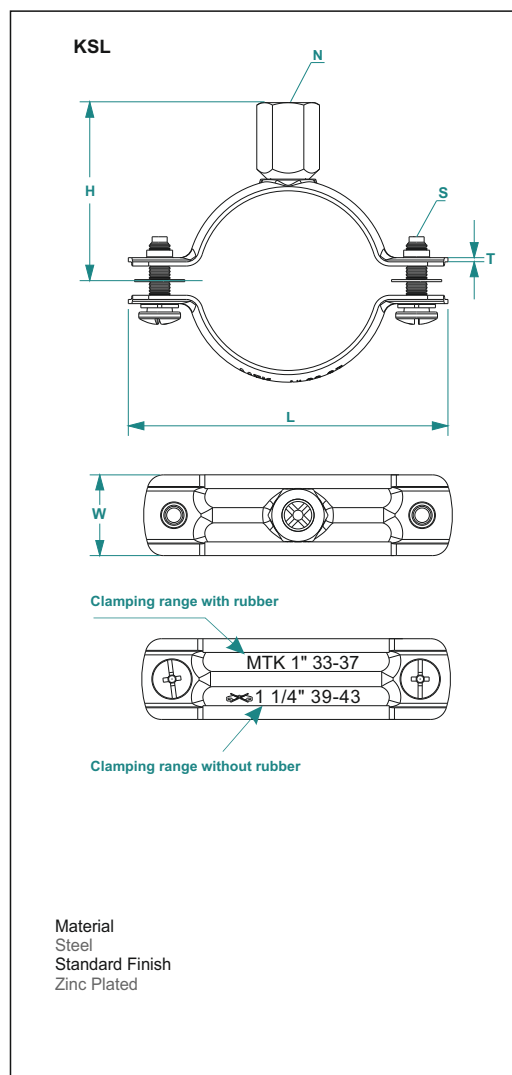

KSL

CODE	SIZE	CLAMPING RANGE (mm)	LENGTH (L) (mm)	HEIGHT (H) (mm)	SHEET (TxW) (mm)	SCREW (S) (metric)	NUT (N) (mm)	BREAKING LOAD (kN)	RECOMMENDED LOAD (kN)	QUANTITY PER BOX (Pcs)	WEIGHT PER BOX (AVERAGE KG)
KSL 010	3/8"	15 - 20	52,1	30,5	1x20	M5	M8 / M10	3,9	1,3	300	12,00
KSL 015	1/2"	19 - 23	54,5	32	1x20	M5	M8 / M10	3,9	1,3	250	10,25
KSL 017	23-28	23 - 28	58,5	34	1x20	M5	M8 / M10	3,9	1,3	250	11,00
KSL 020	3/4"	25 - 30	62,5	36	1x20	M5	M8 / M10	3,9	1,3	200	9,00
KSL 025	1"	31 - 35	68,5	39	1x20	M5	M8 / M10	3,9	1,3	200	9,40
KSL 032	1 1/4"	38 - 43	76	42,5	1x20	M5	M8 / M10	3,9	1,3	150	7,65
KSL 040	1 1/2"	45 - 51	91,5	47	1,2x20	M5	M8 / M10	4,8	1,6	100	6,50
KSL 047	54-58	54 - 58	99	50,5	1,2x20	M5	M8 / M10	4,8	1,6	100	7,00
KSL 050	2"	60 - 65	105	53,5	1,2x20	M5	M8 / M10	4,8	1,6	100	7,30
KSL 060	67-71	67 - 71	112	57	1,2x20	M5	M8 / M10	4,8	1,6	50	4,25
KSL 065	2 1/2"	74 - 82	126	62	1,5x25	M6	M8 / M10	6,9	2,3	50	6,30
KSL 075	82-89	82 - 89	134	66	1,5x25	M6	M8 / M10	6,9	2,3	50	6,60
KSL 080	3"	91 - 98	142	70	1,5x25	M6	M8 / M10	6,9	2,3	50	6,95
KSL 085	93-101	93 - 101	145	71,5	1,5x25	M6	M8 / M10	6,9	2,3	30	4,41
KSL 095	102-109	102 - 109	153	75,5	1,5x25	M6	M8 / M10	6,9	2,3	30	4,80
KSL 100	4"	109 - 117	161	79,5	1,5x25	M6	M8 / M10	6,9	2,3	50	7,90
KSL 110	116-125	116 - 125	170	84	1,5x25	M6	M8 / M10	6,9	2,3	50	8,25
KSL 120	129-141	129 - 141	184	90,5	2x25	M6	M8 / M10	7,8	2,6	50	11,15
KSL 125	5"	136 - 146	190	93,5	2x25	M6	M8 / M10	7,8	2,6	40	9,36
KSL 140	142-154	142 - 154	197	97	2x25	M6	M8 / M10	7,8	2,6	25	6,23
KSL 150	6"	158 - 169	213	105	2x25	M6	M8 / M10	7,8	2,6	30	7,95
KSL 180	166-177	166 - 177	222	109,5	2x25	M6	M8 / M10	7,8	2,6	20	5,74
KSL 190	201-212	201 - 212	257	127	2x25	M6	M8 / M10	7,8	2,6	15	4,88
KSL 200	8"	219 - 229	272	136	2x25	M6	M8 / M10	7,8	2,6	15	5,18

Pipe Clamp With Combi Nut (Set)

Скоба за тръба с комбинирана гайка (комплект)

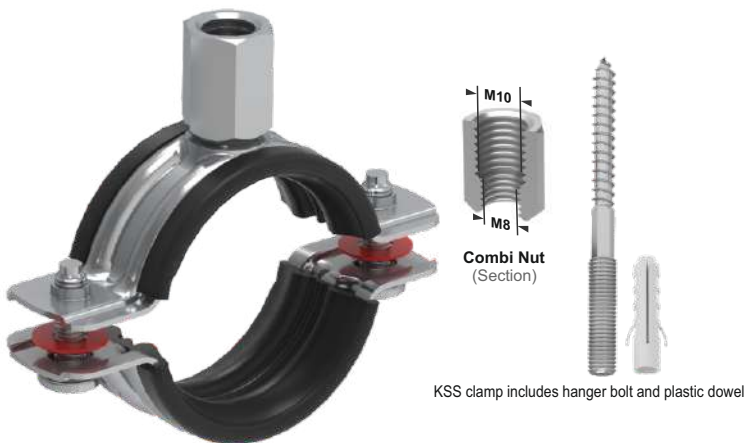

Application

Used with pvc, pe, pp, cast iron, steel and copper pipes.

Package View & Mounting Example

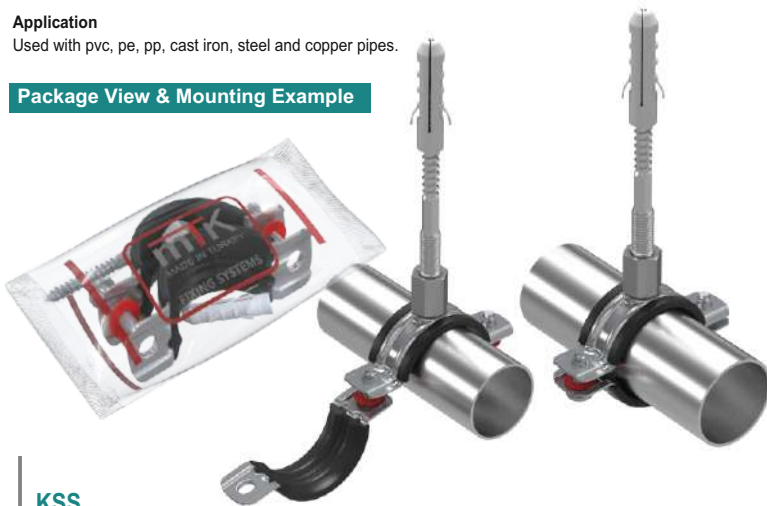

KSS

Material
 Steel
 Standard Finish
 Zinc Plated
Hardness of Rubber Lining
 55 \pm 5 Shore A
Isolation Rubber
 Standard TPE, on request EPDM
Temperature Resistance
 -50 $^{\circ}$ C / +110 $^{\circ}$ C

KSS

CODE	SIZE	CLAMPING RANGE (mm)	LENGTH (L) (mm)	HEIGHT (H) (mm)	SHEET (TxW) (mm)	SCREW (S) (metric)	NUT (N) (mm)	HANGER BOLT (A) (metric)	DOWEL (D) (mm)	BREAKING LOAD (kN)	RECOMMENDED LOAD (kN)	QUANTITY PER BOX (Pcs)	WEIGHT PER BOX (AVERAGE KG)
KSS 006	1/8"	9 - 12	52,1	30,5	1x20	M5	M8 / M10	M8x80	10	3,9	1,3	150	9,45
KSS 008	1/4"	13 - 20	54,5	32	1x20	M5	M8 / M10	M8x80	10	3,9	1,3	120	7,80
KSS 010	3/8"	17 - 23	58,5	34	1x20	M5	M8 / M10	M8x80	10	3,9	1,3	100	6,90
KSS 015	1/2"	20 - 25	62,5	36	1x20	M5	M8 / M10	M8x80	10	3,9	1,3	100	7,10
KSS 020	3/4"	25 - 30	68,5	39	1x20	M5	M8 / M10	M8x80	10	3,9	1,3	100	7,50
KSS 025	1"	32 - 37	76	42,5	1x20	M5	M8 / M10	M8x80	10	3,9	1,3	75	6,08
KSS 032	1 1/4"	40 - 46	91,5	47	1,2x20	M5	M8 / M10	M8x80	10	4,8	1,6	50	4,80
KSS 040	1 1/2"	48 - 53	99	50,5	1,2x20	M5	M8 / M10	M8x80	10	4,8	1,6	50	5,10
KSS 047	53-59	53 - 59	105	53,5	1,2x20	M5	M8 / M10	M8x80	10	4,8	1,6	50	5,35
KSS 050	2"	60 - 66	112	57	1,2x20	M5	M8 / M10	M8x80	10	4,8	1,6	40	4,52
KSS 060	67-77	67 - 77	126	62	1,5x25	M6	M8 / M10	M8x80	10	6,9	2,3	40	6,80
KSS 065	2 1/2"	75 - 84	134	66	1,5x25	M6	M8 / M10	M8x80	10	6,9	2,3	40	7,12
KSS 075	83-93	83 - 93	142	70	1,5x25	M6	M8 / M10	M8x80	10	6,9	2,3	40	7,56
KSS 080	3"	87 - 96	145	71,5	1,5x25	M6	M8 / M10	M8x80	10	6,9	2,3	40	7,72
KSS 085	94-104	94 - 104	153	75,5	1,5x25	M6	M8 / M10	M8x80	10	6,9	2,3	30	6,36
KSS 095	102-111	102 - 111	161	79,5	1,5x25	M6	M8 / M10	M8x80	10	6,9	2,3	30	6,42
KSS 100	4"	109 - 119	170	84	1,5x25	M6	M8 / M10	M8x80	10	6,9	2,3	30	6,72
KSS 110	122-135	122 - 135	184	90,5	2x25	M6	M8 / M10	M10x100	12	7,8	2,6	30	9,24
KSS 120	128-139	128 - 139	190	93,5	2x25	M6	M8 / M10	M10x100	12	7,8	2,6	20	8,68
KSS 125	5"	135 - 148	197	97	2x25	M6	M8 / M10	M10x100	12	7,8	2,6	25	8,35
KSS 140	151-164	151 - 164	213	105	2x25	M6	M8 / M10	M10x100	12	7,8	2,6	20	7,18
KSS 150	6"	158 - 170	222	109,5	2x25	M6	M8 / M10	M10x100	12	7,8	2,6	20	7,60
KSS 180	194-205	194 - 205	257	127	2x25	M6	M8 / M10	M10x100	12	7,8	2,6	10	4,31
KSS 200	8"	214 - 224	272	136	2x25	M6	M8 / M10	M10x100	12	7,8	2,6	10	4,54

Pipe Clamps



ЕНЕРДЖИ ГРУП ООД

Pipe Clamp With Combi Nut Without Rubber (Set)

Скоба за трѐба с комбинирана гайка без гума (Комплект)

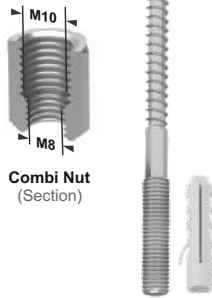

Combi Nut
(Section)

KSLs clamp includes hanger bolt and plastic dowel

Application

Used with pvc, pe, pp, cast iron, steel and copper pipes.

Package View & Mounting Example

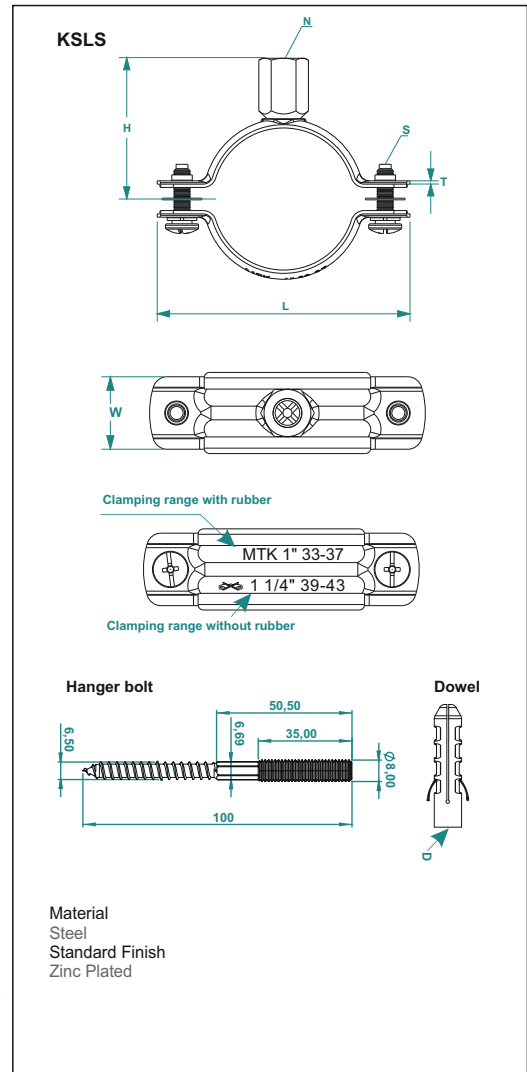
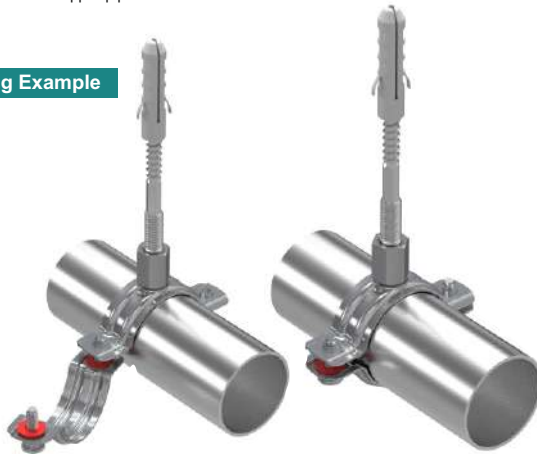

KSLs

CODE	SIZE	CLAMPING RANGE (mm)	LENGTH (L) (mm)	HEIGHT (H) (mm)	SHEET (TxW) (mm)	SCREW (S) (metric)	NUT (N) (mm)	HANGER BOLT (A) (metric)	DOWEL (D) (mm)	BREAKING LOAD (kN)	RECOMMENDED LOAD (kN)	QUANTITY PER BOX (Pcs)	WEIGHT PER BOX (AVERAGE KG)
KSLs 010	3/8"	15 - 20	52,1	30,5	1x20	M5	M8 / M10	M8x80	10	3,9	1,3	150	8,70
KSLs 015	1/2"	19 - 23	54,5	32	1x20	M5	M8 / M10	M8x80	10	3,9	1,3	120	7,08
KSLs 017	23-28	23 - 28	58,5	34	1x20	M5	M8 / M10	M8x80	10	3,9	1,3	100	6,20
KSLs 020	3/4"	25 - 30	62,5	36	1x20	M5	M8 / M10	M8x80	10	3,9	1,3	100	6,40
KSLs 025	1"	31 - 35	68,5	39	1x20	M5	M8 / M10	M8x80	10	3,9	1,3	100	6,60
KSLs 032	1 1/4"	38 - 43	76	42,5	1x20	M5	M8 / M10	M8x80	10	3,9	1,3	75	5,33
KSLs 040	1 1/2"	45 - 51	91,5	47	1,2x20	M5	M8 / M10	M8x80	10	4,8	1,6	50	4,20
KSLs 047	54-58	54 - 58	99	50,5	1,2x20	M5	M8 / M10	M8x80	10	4,8	1,6	50	4,45
KSLs 050	2"	60 - 65	105	53,5	1,2x20	M5	M8 / M10	M8x80	10	4,8	1,6	50	4,60
KSLs 060	67-71	67 - 71	112	57	1,2x20	M5	M8 / M10	M8x80	10	4,8	1,6	50	5,15
KSLs 065	2 1/2"	74 - 82	126	62	1,5x25	M6	M8 / M10	M8x80	10	6,9	2,3	40	5,80
KSLs 075	82-89	82 - 89	134	66	1,5x25	M6	M8 / M10	M8x80	10	6,9	2,3	40	6,04
KSLs 080	3"	91 - 98	142	70	1,5x25	M6	M8 / M10	M8x80	10	6,9	2,3	40	6,32
KSLs 085	93-101	93 - 101	145	71,5	1,5x25	M6	M8 / M10	M8x80	10	6,9	2,3	40	6,48
KSLs 095	102-109	102 - 109	153	75,5	1,5x25	M6	M8 / M10	M8x80	10	6,9	2,3	30	5,31
KSLs 100	4"	109 - 117	161	79,5	1,5x25	M6	M8 / M10	M8x80	10	6,9	2,3	30	5,31
KSLs 110	116-125	116 - 125	170	84	1,5x25	M6	M8 / M10	M10x100	12	6,9	2,3	30	6,12
KSLs 120	129-141	129 - 141	184	90,5	2x25	M6	M8 / M10	M10x100	12	7,8	2,6	30	7,89
KSLs 125	5"	136 - 146	190	93,5	2x25	M6	M8 / M10	M10x100	12	7,8	2,6	25	6,83
KSLs 140	142-154	142 - 154	197	97	2x25	M6	M8 / M10	M10x100	12	7,8	2,6	20	5,70
KSLs 150	6"	158 - 169	213	105	2x25	M6	M8 / M10	M10x100	12	7,8	2,6	20	6,06
KSLs 180	166-177	166 - 177	222	109,5	2x25	M6	M8 / M10	M10x100	12	7,8	2,6	20	6,46
KSLs 190	201-212	201 - 212	257	127	2x25	M6	M8 / M10	M10x100	12	7,8	2,6	10	3,61
KSLs 200	8"	219 - 229	272	136	2x25	M6	M8 / M10	M10x100	12	7,8	2,6	10	3,81

Pipe Clamp With Triphone

Скоба за тръба с трифон



Application

Used with pvc, pe, pp, cast iron, steel and copper pipes.

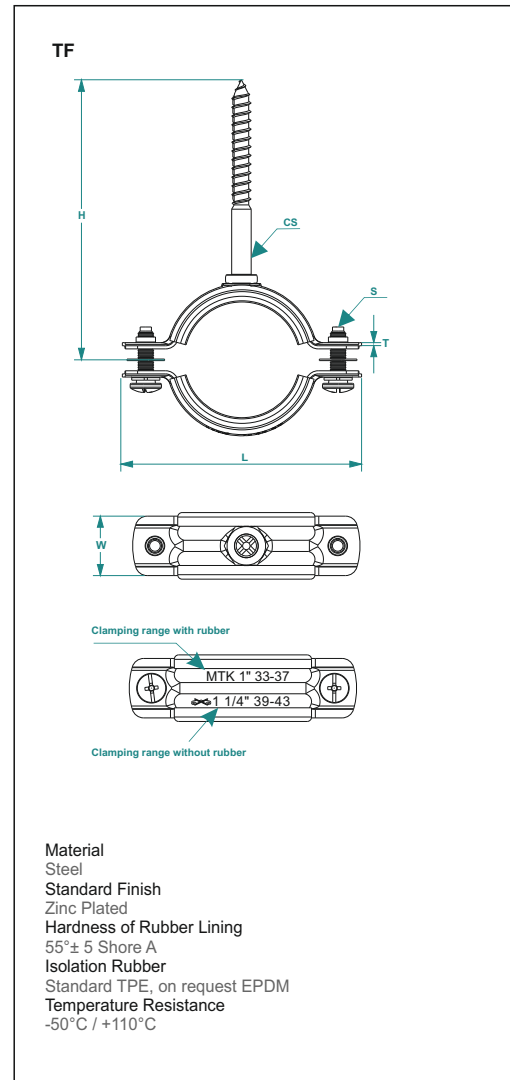

TF

CODE	SIZE	CLAMPING RANGE (mm)	LENGTH (L) (mm)	HEIGHT (H) (mm)	SHEET (TxW) (mm)	SCREW (S) (metric)	COACH SCREW (CS) (mm)	BREAKING LOAD (kN)	RECOMMENDED LOAD (kN)	QUANTITY PER BOX (Pcs)	WEIGHT PER BOX (AVERAGE KG)
TF 006	1/8"	9 - 12	52,1	82	1x20	M5	Ø7x70	3,9	1,3	200	9,00
TF 008	1/4"	13 - 20	54,5	84	1x20	M5	Ø7x70	3,9	1,3	200	9,20
TF 010	3/8"	17 - 23	58,5	86	1x20	M5	Ø7x70	3,9	1,3	150	7,35
TF 015	1/2"	20 - 25	62,5	88	1x20	M5	Ø7x70	3,9	1,3	150	7,80
TF 020	3/4"	25 - 30	68,5	91	1x20	M5	Ø7x70	3,9	1,3	125	7,00
TF 025	1"	32 - 37	76	94,5	1x20	M5	Ø7x70	3,9	1,3	100	6,10
TF 032	1 1/4"	40 - 46	91,5	99	1,2x20	M5	Ø7x70	4,8	1,6	75	5,78
TF 040	1 1/2"	48 - 53	99	102,5	1,2x20	M5	Ø7x70	4,8	1,6	50	4,25
TF 047	53-59	53 - 59	105	105,5	1,2x20	M5	Ø7x70	4,8	1,6	50	4,45
TF 050	2"	60 - 66	112	109	1,2x20	M5	Ø7x70	4,8	1,6	50	4,75
TF 060	67-77	67 - 77	126	114	1,5x25	M6	Ø7x70	6,9	2,3	20	3,18
TF 065	2 1/2"	75 - 84	134	118	1,5x25	M6	Ø7x70	6,9	2,3	25	4,10
TF 075	83-93	83 - 93	142	122	1,5x25	M6	Ø7x70	6,9	2,3	20	3,54
TF 080	3"	87 - 96	145	123,5	1,5x25	M6	Ø7x70	6,9	2,3	20	3,64
TF 085	94-104	94 - 104	153	127,5	1,5x25	M6	Ø7x70	6,9	2,3	20	3,96
TF 095	102-111	102 - 111	161	131,5	1,5x25	M6	Ø7x70	6,9	2,3	15	3,09
TF 100	4"	109 - 119	170	136	1,5x25	M6	Ø7x70	6,9	2,3	15	3,23
TF 110	122-135	122 - 135	184	142,5	2x25	M6	Ø7x70	7,8	2,6	15	4,17
TF 120	128-139	128 - 139	190	145,5	2x25	M6	Ø7x70	7,8	2,6	10	2,97
TF 125	5"	135 - 148	197	149	2x25	M6	Ø7x70	7,8	2,6	10	3,10
TF 140	151-164	151 - 164	213	157	2x25	M6	Ø7x70	7,8	2,6	10	3,34
TF 150	6"	158 - 170	222	161,5	2x25	M6	Ø7x70	7,8	2,6	10	3,52
TF 180	194-205	194 - 205	257	179	2x25	M6	Ø7x70	7,8	2,6	5	3,98
TF 200	8"	214 - 224	272	188	2x25	M6	Ø7x70	7,8	2,6	5	2,11

Pipe Clamp With Triphone without Rubber

Скоба за тръба с трифон без гума

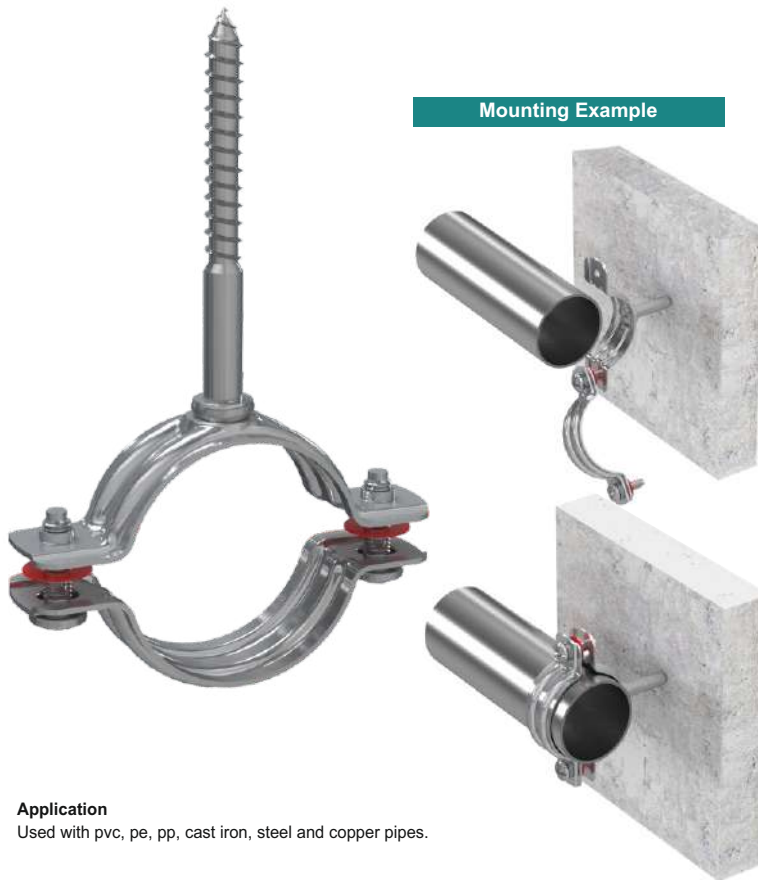

Application

Used with pvc, pe, pp, cast iron, steel and copper pipes.

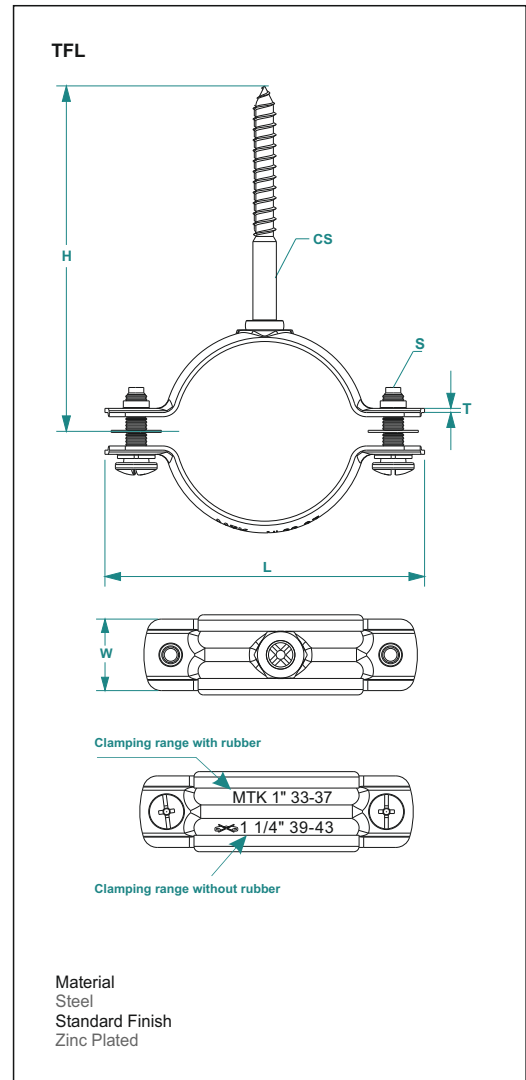

TFL

CODE	SIZE	CLAMPING RANGE (mm)	LENGTH (L) (mm)	HEIGHT (H) (mm)	SHEET (TxW) (mm)	SCREW (S) (metric)	COACH SCREW (CS) (mm)	BREAKING LOAD (kN)	RECOMMENDED LOAD (kN)	QUANTITY PER BOX (Pcs)	WEIGHT PER BOX (AVERAGE KG)
TFL 010	3/8"	15 - 20	52,1	82	1x20	M5	Ø7x70	3,9	1,3	200	8,20
TFL 015	1/2"	19 - 23	54,5	84	1x20	M5	Ø7x70	3,9	1,3	200	8,40
TFL 017	23-28	23 - 28	58,5	86	1x20	M5	Ø7x70	3,9	1,3	100	4,60
TFL 020	3/4"	25 - 30	62,5	88	1x20	M5	Ø7x70	3,9	1,3	150	6,90
TFL 025	1"	31 - 35	68,5	91	1x20	M5	Ø7x70	3,9	1,3	150	7,35
TFL 032	1 1/4"	38 - 43	76	94,5	1x20	M5	Ø7x70	3,9	1,3	150	7,80
TFL 040	1 1/2"	45 - 51	91,5	99	1,2x20	M5	Ø7x70	4,8	1,6	100	6,60
TFL 047	54-58	54 - 58	99	102,5	1,2x20	M5	Ø7x70	4,8	1,6	75	5,40
TFL 050	2"	60 - 65	105	105,5	1,2x20	M5	Ø7x70	4,8	1,6	75	5,63
TFL 060	67-71	67 - 71	112	109	1,2x20	M5	Ø7x70	4,8	1,6	50	4,30
TFL 065	2 1/2"	74 - 82	126	114	1,5x25	M6	Ø7x70	6,9	2,3	50	6,35
TFL 075	82-89	82 - 89	134	118	1,5x25	M6	Ø7x70	6,9	2,3	50	6,65
TFL 080	3"	91 - 98	142	122	1,5x25	M6	Ø7x70	6,9	2,3	50	7,00
TFL 085	93-101	93 - 101	145	123,5	1,5x25	M6	Ø7x70	6,9	2,3	40	5,80
TFL 095	102-109	102 - 109	153	127,5	1,5x25	M6	Ø7x70	6,9	2,3	15	2,55
TFL 100	4"	109 - 117	161	131,5	1,5x25	M6	Ø7x70	6,9	2,3	25	4,10
TFL 110	116-125	116 - 125	170	136	1,5x25	M6	Ø7x70	6,9	2,3	15	2,67
TFL 120	129-141	129 - 141	184	142,5	2x25	M6	Ø7x70	7,8	2,6	15	3,56
TFL 125	5"	136 - 146	190	145,5	2x25	M6	Ø7x70	7,8	2,6	10	2,56
TFL 140	142-154	142 - 154	197	149	2x25	M6	Ø7x70	7,8	2,6	10	2,66
TFL 150	6"	158 - 169	213	157	2x25	M6	Ø7x70	7,8	2,6	10	2,84
TFL 180	166-177	166 - 177	222	161,5	2x25	M6	Ø7x70	7,8	2,6	10	3,02
TFL 190	201-212	201 - 212	257	179	2x25	M6	Ø7x70	7,8	2,6	10	3,35
TFL 200	8"	219 - 229	272	188	2x25	M6	Ø7x70	7,8	2,6	10	3,55

Pipe Clamp With Triphone (Long Type)

Скоба за тръба с трифон (дълъг тип)



Application

Used with pvc, pe, pp, cast iron, steel and copper pipes.

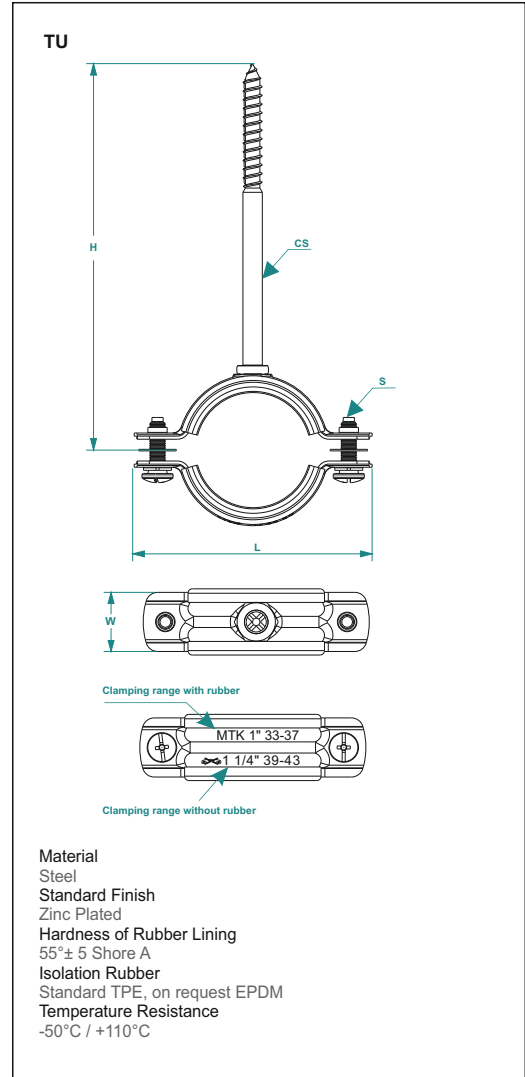

TU

CODE	SIZE	CLAMPING RANGE	LENGTH	HEIGHT	SHEET	SCREW	COACH SCREW	BREAKING	RECOMMENDED	QUANTITY	WEIGHT PER BOX
		(mm)	(L) (mm)	(H) (mm)	(TxW) (mm)	(S) (metric)	(CS) (mm)	LOAD (kN)	LOAD (kN)	PER BOX (Pcs)	(AVERAGE KG)
TU 006	1/8"	9 - 12	52,1	112,5	1x20	M5	Ø7x100	3,9	1,3	150	8,250
TU 008	1/4"	13 - 20	54,5	114	1x20	M5	Ø7x100	3,9	1,3	150	8,550
TU 010	3/8"	17 - 23	58,5	116	1x20	M5	Ø7x100	3,9	1,3	150	8,850
TU 015	1/2"	20 - 25	62,5	118	1x20	M5	Ø7x100	3,9	1,3	150	9,300
TU 020	3/4"	25 - 30	68,5	121	1x20	M5	Ø7x100	3,9	1,3	100	6,600
TU 025	1"	32 - 37	76	124,5	1x20	M5	Ø7x100	3,9	1,3	75	5,400
TU 032	1 1/4"	40 - 46	91,5	129	1,2x20	M5	Ø7x100	4,8	1,6	50	4,400
TU 040	1 1/2"	48 - 53	99	132,5	1,2x20	M5	Ø7x100	4,8	1,6	50	4,750
TU 047	53-59	53 - 59	105	135,5	1,2x20	M5	Ø7x100	4,8	1,6	50	4,950
TU 050	2"	60 - 66	112	139	1,2x20	M5	Ø7x100	4,8	1,6	40	4,240
TU 060	67-77	67 - 77	126	144	1,5x25	M6	Ø7x100	6,9	2,3	25	4,150
TU 065	2 1/2"	75 - 84	134	148	1,5x25	M6	Ø7x100	6,9	2,3	20	3,540
TU 075	83-93	83 - 93	142	152	1,5x25	M6	Ø7x100	6,9	2,3	20	3,740
TU 080	3"	87 - 96	145	153,5	1,5x25	M6	Ø7x100	6,9	2,3	20	3,840
TU 085	94-104	94 - 104	153	157,5	1,5x25	M6	Ø7x100	6,9	2,3	20	4,160
TU 095	102-111	102 - 111	161	161,5	1,5x25	M6	Ø7x100	6,9	2,3	15	3,240
TU 100	4"	109 - 119	170	166	1,5x25	M6	Ø7x100	6,9	2,3	15	3,380
TU 110	122-135	122 - 135	184	172,5	2x25	M6	Ø7x100	7,8	2,6	15	4,320
TU 120	128-139	128 - 139	190	175,5	2x25	M6	Ø7x100	7,8	2,6	10	3,07
TU 125	5"	135 - 148	197	179	2x25	M6	Ø7x100	7,8	2,6	10	3,20
TU 140	151-164	151 - 164	213	187	2x25	M6	Ø7x100	7,8	2,6	10	3,44
TU 150	6"	158 - 170	222	191,5	2x25	M6	Ø7x100	7,8	2,6	10	3,62
TU 180	194-205	194 - 205	257	209	2x25	M6	Ø7x100	7,8	2,6	5	2,04
TU 200	8"	214 - 224	272	218	2x25	M6	Ø7x100	7,8	2,6	5	2,16

Pipe Clamps



ЕНЕРДЖИ ГРУП ООД

Pipe Clamp with Triphone (Long type - Without Rubber)

Скоба за тръба с трифон (дълъг тип - без гума)



Application

Used with pvc, pe, pp, cast iron, steel and copper pipes.

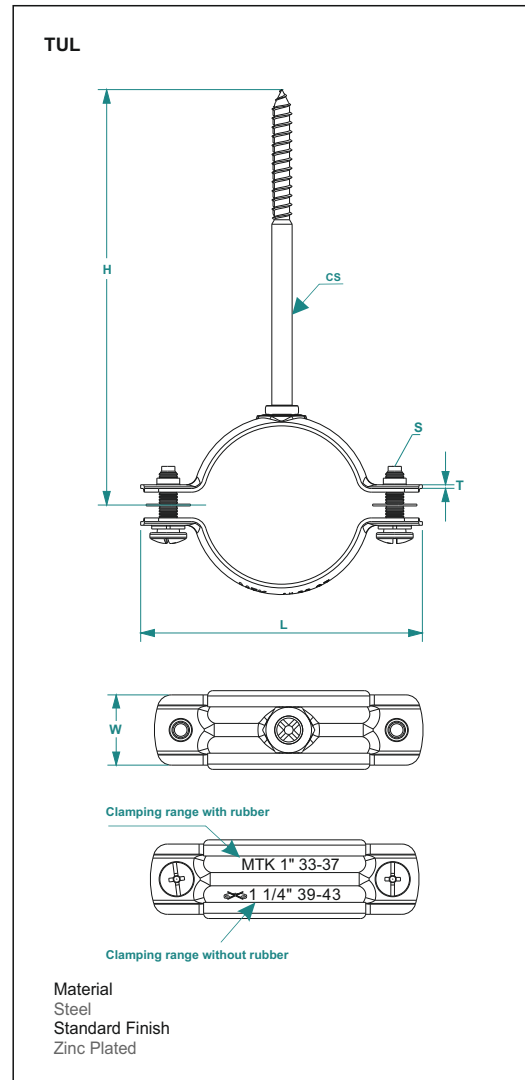

TUL

CODE	SIZE	CLAMPING RANGE (mm)	LENGTH (L) (mm)	HEIGHT (H) (mm)	SHEET (TxW) (mm)	SCREW (S) (metric)	COACH SCREW (CS) (mm)	BREAKING LOAD (kN)	RECOMMENDED LOAD (kN)	QUANTITY PER BOX (Pcs)	WEIGHT PER BOX (AVERAGE KG)
TUL 010	3/8"	15 - 20	52,1	112,5	1x20	M5	Ø7x100	3,9	1,3	200	10,20
TUL 015	1/2"	19 - 23	54,5	114	1x20	M5	Ø7x100	3,9	1,3	200	10,40
TUL 017	23-28	23 - 28	58,5	116	1x20	M5	Ø7x100	3,9	1,3	100	5,60
TUL 020	3/4"	25 - 30	62,5	118	1x20	M5	Ø7x100	3,9	1,3	150	8,40
TUL 025	1"	31 - 35	68,5	121	1x20	M5	Ø7x100	3,9	1,3	150	8,85
TUL 032	1 1/4"	38 - 43	76	124,5	1x20	M5	Ø7x100	3,9	1,3	100	6,30
TUL 040	1 1/2"	45 - 51	91,5	129	1,2x20	M5	Ø7x100	4,8	1,6	75	5,78
TUL 047	54-58	54 - 58	99	132,5	1,2x20	M5	Ø7x100	4,8	1,6	75	6,15
TUL 050	2"	60 - 65	105	135,5	1,2x20	M5	Ø7x100	4,8	1,6	75	6,38
TUL 060	67-71	67 - 71	112	139	1,2x20	M5	Ø7x100	4,8	1,6	50	4,80
TUL 065	2 1/2"	74 - 82	126	144	1,5x25	M6	Ø7x100	6,9	2,3	30	4,23
TUL 075	82-89	82 - 89	134	148	1,5x25	M6	Ø7x100	6,9	2,3	30	4,41
TUL 080	3"	91 - 98	142	152	1,5x25	M6	Ø7x100	6,9	2,3	30	4,62
TUL 085	93-101	93 - 101	145	153,5	1,5x25	M6	Ø7x100	6,9	2,3	20	3,24
TUL 095	102-109	102 - 109	153	157,5	1,5x25	M6	Ø7x100	6,9	2,3	15	2,70
TUL 100	4"	109 - 117	161	161,5	1,5x25	M6	Ø7x100	6,9	2,3	15	2,73
TUL 110	116-125	116 - 125	170	166	1,5x25	M6	Ø7x100	6,9	2,3	15	2,82
TUL 120	129-141	129 - 141	184	172,5	2x25	M6	Ø7x100	7,8	2,6	15	3,71
TUL 125	5"	136 - 146	190	175,5	2x25	M6	Ø7x100	7,8	2,6	10	2,66
TUL 140	142-154	142 - 154	197	179	2x25	M6	Ø7x100	7,8	2,6	10	2,76
TUL 150	6"	158 - 169	213	187	2x25	M6	Ø7x100	7,8	2,6	10	2,94
TUL 180	166-177	166 - 177	222	191,5	2x25	M6	Ø7x100	7,8	2,6	10	3,12
TUL 190	201-212	201 - 212	257	209	2x25	M6	Ø7x100	7,8	2,6	5	1,73
TUL 200	8"	219 - 229	272	218	2x25	M6	Ø7x100	7,8	2,6	5	1,92

Pipe Clamp With Triphone (Set)

Скоба за трѝба с трифон (Комплект)

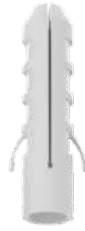

TFS clamp includes plastic dowel

Application

Used with pvc, pe, pp, cast iron, steel and copper pipes.

Mounting Example



TFS

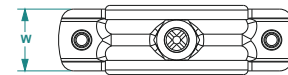
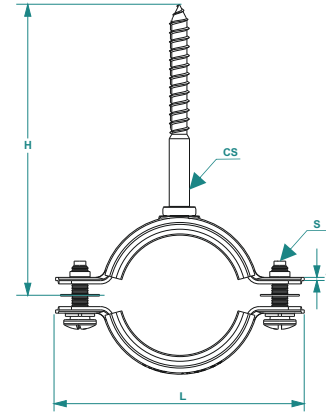

Clamping range with rubber

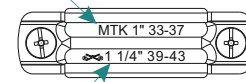

Clamping range without rubber



Material

Steel

Standard Finish

Zinc Plated

Hardness of Rubber Lining

55 \pm 5 Shore A

Isolation Rubber

Standard TPE, on request EPDM

Temperature Resistance

-50 $^{\circ}$ C / +110 $^{\circ}$ C

TFS

ÜRÜN KODU CODE	ÖLÇÜ SIZE	SIKMA ARALIĞI CLAMPING RANGE (mm)	UZUNLUK LENGTH (L) (mm)	YÜKSEKLİK HEIGHT (H) (mm)	SAC SHEET (TxW)	VIDA SCREW (S) (metric)	TRIFON COACH SCREW (CS) (mm)	DÜBEL DOWEL (D) (mm)	KOPMA YÜKÜ BREAKING LOAD (kN)	ÇALIŞMA YÜKÜ RECOMMENDED LOAD (kN)	KOLİDEKİ ADET QUANTITY PER BOX (Pcs)	KOLİ AĞIRLIĞI WEIGHT PER BOX (ORTALAMA KG AVERAGE KG)
TFS 006	1/8"	9 - 12	52,1	82	1x20	M5	Ø7x70	10	3,9	1,3	200	9,71
TFS 008	1/4"	13 - 20	54,5	84	1x20	M5	Ø7x70	10	3,9	1,3	200	9,94
TFS 010	3/8"	17 - 23	58,5	86	1x20	M5	Ø7x70	10	3,9	1,3	150	8,06
TFS 015	1/2"	20 - 25	62,5	88	1x20	M5	Ø7x70	10	3,9	1,3	150	8,36
TFS 020	3/4"	25 - 30	68,5	91	1x20	M5	Ø7x70	10	3,9	1,3	125	7,59
TFS 025	1"	32 - 37	76	94,5	1x20	M5	Ø7x70	10	3,9	1,3	100	6,67
TFS 032	1 1/4"	40 - 46	91,5	99	1,2x20	M5	Ø7x70	10	4,8	1,6	75	6,13
TFS 040	1 1/2"	48 - 53	99	102,5	1,2x20	M5	Ø7x70	10	4,8	1,6	50	4,49
TFS 047	53-59	53 - 59	105	105,5	1,2x20	M5	Ø7x70	10	4,8	1,6	50	4,74
TFS 050	2"	60 - 66	112	109	1,2x20	M5	Ø7x70	10	4,8	1,6	50	5,04
TFS 060	67-77	67 - 77	126	114	1,5x25	M6	Ø7x70	10	6,9	2,3	20	3,21
TFS 065	2 1/2"	75 - 84	134	118	1,5x25	M6	Ø7x70	10	6,9	2,3	25	4,14
TFS 075	83-93	83 - 93	142	122	1,5x25	M6	Ø7x70	10	6,9	2,3	20	3,57
TFS 080	3"	87 - 96	145	123,5	1,5x25	M6	Ø7x70	10	6,9	2,3	20	3,67
TFS 085	94-104	94 - 104	153	127,5	1,5x25	M6	Ø7x70	10	6,9	2,3	20	3,99
TFS 095	102-111	102 - 111	161	131,5	1,5x25	M6	Ø7x70	10	6,9	2,3	15	3,11
TFS 100	4"	109 - 119	170	136	1,5x25	M6	Ø7x70	10	6,9	2,3	15	3,24
TFS 110	122-135	122 - 135	184	142,5	2x25	M6	Ø7x70	10	7,8	2,6	15	4,20
TFS 120	128-139	128 - 139	190	145,5	2x25	M6	Ø7x70	10	7,8	2,6	10	2,99
TFS 125	5"	135 - 148	197	149	2x25	M6	Ø7x70	10	7,8	2,6	10	3,12
TFS 140	151-164	151 - 164	213	157	2x25	M6	Ø7x70	10	7,8	2,6	10	3,36
TFS 150	6"	158 - 170	222	161,5	2x25	M6	Ø7x70	10	7,8	2,6	10	3,54
TFS 180	194-205	194 - 205	257	179	2x25	M6	Ø7x70	10	7,8	2,6	5	2,01
TFS 200	8"	214 - 224	272	188	2x25	M6	Ø7x70	10	7,8	2,6	5	2,12

Pipe Clamp With triphone (Set) Without Rubber

Скоба за тръба с трифон (Комплект) Без гума

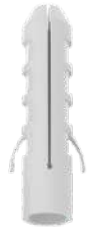

TFLS clamp includes plastic dowel

Application

Used with pvc, pe, pp, cast iron, steel and copper pipes.

Mounting Example

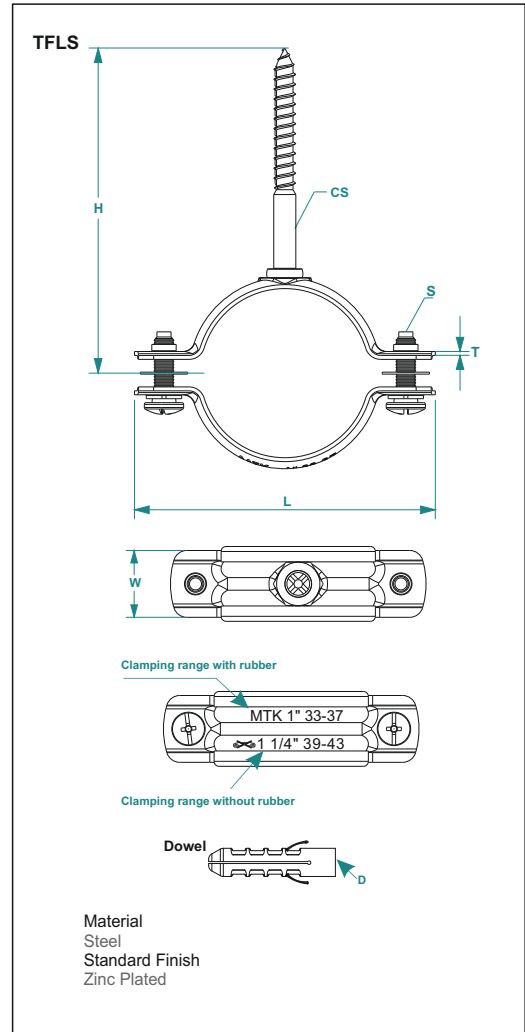

TFLS

CODE	SIZE	CLAMPING RANGE (mm)	LENGTH (L) (mm)	HEIGHT (H) (mm)	SHEET (TxW)	SCREW (S) (metric)	COACH SCREW (CS) (mm)	DOWEL (D) (mm)	BREAKING LOAD (kN)	RECOMMENDED LOAD (kN)	QUANTITY PER BOX (Pcs)	WEIGHT PER BOX (AVERAGE KG)
TFLS 010	3/8"	15 - 20	52,1	82	1x20	M5	Ø7x70	10	3,9	1,3	200	8,60
TFLS 015	1/2"	19 - 23	54,5	84	1x20	M5	Ø7x70	10	3,9	1,3	200	8,80
TFLS 017	23-28	23 - 28	58,5	86	1x20	M5	Ø7x70	10	3,9	1,3	100	4,70
TFLS 020	3/4"	25 - 30	62,5	88	1x20	M5	Ø7x70	10	3,9	1,3	150	7,20
TFLS 025	1"	31 - 35	68,5	91	1x20	M5	Ø7x70	10	3,9	1,3	150	7,65
TFLS 032	1 1/4"	38 - 43	76	94,5	1x20	M5	Ø7x70	10	3,9	1,3	150	8,10
TFLS 040	1 1/2"	45 - 51	91,5	99	1,2x20	M5	Ø7x70	10	4,8	1,6	100	6,80
TFLS 047	54-58	54 - 58	99	102,5	1,2x20	M5	Ø7x70	10	4,8	1,6	75	5,48
TFLS 050	2"	60 - 65	105	105,5	1,2x20	M5	Ø7x70	10	4,8	1,6	75	5,78
TFLS 060	67-71	67 - 71	112	109	1,2x20	M5	Ø7x70	10	4,8	1,6	50	4,10
TFLS 065	2 1/2"	74 - 82	126	114	1,5x25	M6	Ø7x70	10	6,9	2,3	50	6,44
TFLS 075	82-89	82 - 89	134	118	1,5x25	M6	Ø7x70	10	6,9	2,3	50	6,75
TFLS 080	3"	91 - 98	142	122	1,5x25	M6	Ø7x70	10	6,9	2,3	50	7,10
TFLS 085	93-101	93 - 101	145	123,5	1,5x25	M6	Ø7x70	10	6,9	2,3	40	5,88
TFLS 095	102-109	102 - 109	153	127,5	1,5x25	M6	Ø7x70	10	6,9	2,3	15	2,58
TFLS 100	4"	109 - 117	161	131,5	1,5x25	M6	Ø7x70	10	6,9	2,3	25	4,15
TFLS 110	116-125	116 - 125	170	136	1,5x25	M6	Ø7x70	10	6,9	2,3	15	2,70
TFLS 120	129-141	129 - 141	184	142,5	2x25	M6	Ø7x70	10	7,8	2,6	15	3,59
TFLS 125	5"	136 - 146	190	145,5	2x25	M6	Ø7x70	10	7,8	2,6	10	2,58
TFLS 140	142-154	142 - 154	197	149	2x25	M6	Ø7x70	10	7,8	2,6	10	2,68
TFLS 150	6"	158 - 169	213	157	2x25	M6	Ø7x70	10	7,8	2,6	10	2,86
TFLS 180	166-177	166 - 177	222	161,5	2x25	M6	Ø7x70	10	7,8	2,6	10	3,03
TFLS 190	201-212	201 - 212	257	179	2x25	M6	Ø7x70	10	7,8	2,6	10	3,37
TFLS 200	8"	219 - 229	272	188	2x25	M6	Ø7x70	10	7,8	2,6	10	3,56

Pipe Clamp With Heavy Duty Head

Скоба за трѳба с тежка глава



Application

Used with HDPE, Cast Iron, Steel and Wavin pipes.

Mounting Example



AK

Material
 Steel
 Standard Finish
 Zinc Plated
Hardness of Rubber Lining
 55 \pm 5 Shore A
Isolation Rubber
 Standard TPE, on request EPDM
Temperature Resistance
 -50 $^{\circ}$ C / +110 $^{\circ}$ C

AK

CODE	SIZE	CLAMPING RANGE	LENGTH (L) (mm)	HEIGHT (H) (mm)	SHEET (TxW) (mm)	HEAD (K) (mm)	SLOT HOLE (SxH) (mm)	BOLT (B) (metric)	BREAKING LOAD (kN)	RECOMMENDED LOAD (kN)	QUANTITY PER BOX (Pcs)	WEIGHT (AVERAGE KG) (kg)
AK 008	1/4"	12 - 17	75	40	2x25	2x25x40	10,5x14	M8 (6,8)	10	2,75	50	7,35
AK 015	1/2"	21 - 28	81	41	2x25	2x25x40	10,5x14	M8 (6,8)	10	2,75	50	7,75
AK 020	3/4"	25 - 32	87	42,5	2x25	2x25x40	10,5x14	M8 (6,8)	10	2,75	50	8,20
AK 025	1	33 - 40	94	49,5	2x25	2x25x40	10,5x14	M8 (6,8)	10	2,75	50	8,65
AK 032	1 1/4"	41 - 48	103	55	2x25	2x25x40	10,5x14	M8 (6,8)	10	2,75	40	7,24
AK 040	1 1/2"	48 - 53	111	59	2x25	2x25x40	10,5x14	M8 (6,8)	10	2,75	40	7,68
AK 047	5/8 - 5/8	53 - 59	120	63	2x25	2x25x40	10,5x14	M8 (6,8)	10	2,75	30	6,57
AK 050	2"	60 - 69	125	66	2x25	2x25x40	10,5x14	M8 (6,8)	10	2,75	30	6,33
AK 060	6/8 - 7/8	67 - 75	134	70	2x25	2x25x40	10,5x14	M8 (6,8)	10	2,75	25	7,00
AK 065	2 1/2"	75 - 81	141	74	2x25	2x25x40	10,5x14	M8 (6,8)	10	2,75	25	5,93
AK 075	83-91	83 - 91	149	78	2x25	2x25x40	10,5x14	M8 (6,8)	10	2,75	30	7,62
AK 080	3"	87 - 95	154	80	2x25	2x25x40	10,5x14	M8 (6,8)	10	2,75	30	7,56
AK 085	95 - 104	95 - 104	161	84,5	2x25	2x25x40	10,5x14	M8 (6,8)	10	2,75	25	7,20
AK 095	102 - 112	102 - 112	169	88,5	2,5x30	3x30x40	12x14	M8 (6,8)	14	3,75	25	10,15
AK 100	4"	109 - 119	178	93	2,5x30	3x30x40	12x14	M8 (6,8)	14	3,75	25	10,73
AK 110	122 - 138"	122 - 138	192	101	3x30	3x30x40	12x14	M10 (8,8)	20	6	10	5,70
AK 120	128 - 141	128 - 141	197	103,5	3x30	3x30x40	12x14	M10 (8,8)	20	6	10	5,99
AK 125	5"	136 - 147	204	107	3x30	3x30x40	12x14	M10 (8,8)	20	6	10	6,02
AK 140	153 - 164	153 - 164	220	115	3x30	3x30x40	12x14	M10 (8,8)	20	6	10	6,45
AK 150	6"	164 - 174	229	120	3x30	3x30x40	12x14	M10 (8,8)	20	6	10	6,79
AK 180	196 - 209	196 - 209	264	137	3x30	3x30x40	12x14	M10 (8,8)	20	6	20	15,20
AK 200	8"	214 - 226	279	145	4x30	4x30x40	12x14	M10 (8,8)	20	6	15	15,23
AK 240	240 - 250	240 - 250	310	170	4x30	4x40x40	12x14	M10 (8,8)	20	6	15	16,01
AK 250	10"	266 - 274	335	173	4x30	4x30x40	12x14	M10 (8,8)	20	6	15	18,45
AK 300	12"	308 - 324	400	184	4x40	4x40x40	12,5x23	M12 (8,8)	35	11,7	10	19,10
AK 350	14"	340 - 356	432	221	4x40	4x40x40	12,5x23	M12 (8,8)	35	11,7	8	16,78
AK 380	380 - 390	380 - 390	505	253	5x50	5x50x60	17x25	M16 (8,8)	37	13	5	18,10
AK 400	16"	393 - 409	537	265	5x50	5x50x60	17x25	M16 (8,8)	37	13	5	19,91
AK 450	18"	444 - 460	590	301	5x50	5x50x60	17x25	M16 (8,8)	37	13	5	21,91
AK 500	20"	497 - 512	645	325	5x50	5x50x60	17x25	M16 (8,8)	37	13	4	19,12

Pipe Clamp with Heavy Duty Head / Without Rubber

Скоба за трѐба с тежка глава / Без гума



Application

Used with HDPE, Cast Iron, Steel and Wavin pipes.

Mounting Example

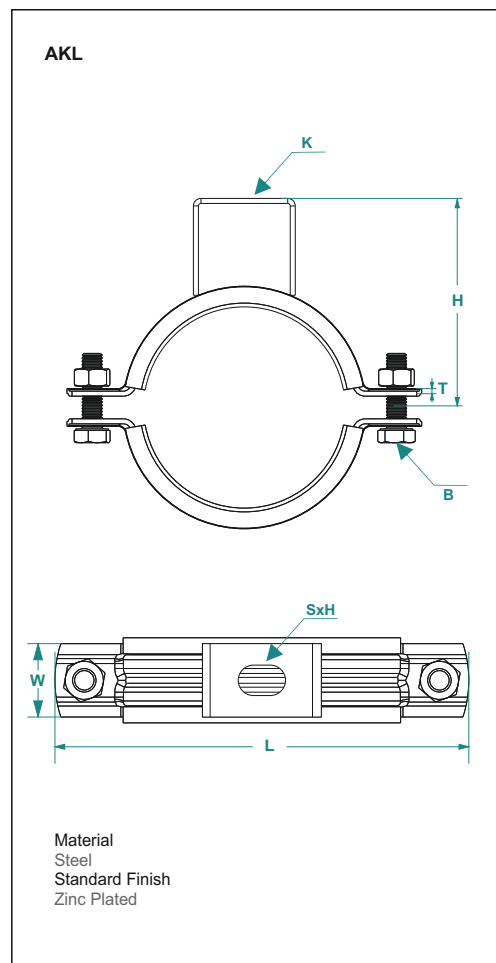

AKL

CODE	SIZE	CLAMPING RANGE	LENGTH (L) (mm)	HEIGHT (H) (mm)	SHEET (TxW) (mm)	HEAD (K) (mm)	SLOT HOLE (SxH) (mm)	BOLT (B) (metric)	BREAKING LOAD (kN)	RECOMMENDED LOAD (kN)	QUANTITY PER BOX (Pcs)	WEIGHT (AVERAGE KG) (kg)
AKL 015	1/2"	18 - 23	75	40	2x25	2x25x40	10,5x14	M8 (6.8)	10,00	2,75	50	6,95
AKL 020	3/4"	26 - 31	81	41	2x25	2x25x40	10,5x14	M8 (6.8)	10,00	2,75	50	7,30
AKL 025	1"	31 - 37	87	42,5	2x25	2x25x40	10,5x14	M8 (6.8)	10,00	2,75	50	7,60
AKL 032	1 1/4"	38 - 44	94	49,5	2x25	2x25x40	10,5x14	M8 (6.8)	10,00	2,75	50	8,00
AKL 040	1 1/2"	46 - 53	103	55	2x25	2x25x40	10,5x14	M8 (6.8)	10,00	2,75	50	8,50
AKL 047	54-60	54 - 60	111	59	2x25	2x25x40	10,5x14	M8 (6.8)	10,00	2,75	40	7,24
AKL 050	2"	60 - 68	120	63	2x25	2x25x40	10,5x14	M8 (6.8)	10,00	2,75	40	7,64
AKL 060	66-73	66 - 73	125	66	2x25	2x25x40	10,5x14	M8 (6.8)	10,00	2,75	40	7,88
AKL 065	2 1/2"	74 - 81	134	70	2x25	2x25x40	10,5x14	M8 (6.8)	10,00	2,75	30	6,30
AKL 075	82-88	82 - 88	141	74	2x25	2x25x40	10,5x14	M8 (6.8)	10,00	2,75	30	6,57
AKL 080	3"	88 - 97	149	78	2x25	2x25x40	10,5x14	M8 (6.8)	10,00	2,75	30	6,84
AKL 085	93-100	93 - 100	154	80	2x25	2x25x40	10,5x14	M8 (6.8)	10,00	2,75	25	5,85
AKL 095	101-109	101 - 109	161	84,5	2x25	2x25x40	10,5x14	M8 (6.8)	10,00	2,75	25	6,08
AKL 100	4"	110 - 118	169	88,5	2,5x30	3x30x40	12x14	M8 (6.8)	14,00	3,75	25	8,90
AKL 110	116-126	116 - 126	178	93	2,5x30	3x30x40	12x14	M8 (6.8)	14,00	3,75	25	9,23
AKL 120	130-141	130 - 141	192	101	3x30	3x30x40	12x14	M10 (8.8)	20,00	6,00	10	5,31
AKL 125	5"	136 - 145	197	103,5	3x30	3x30x40	12x14	M10 (8.8)	20,00	6,00	10	5,42
AKL 140	144-154	144 - 154	204	107	3x30	3x30x40	12x14	M10 (8.8)	20,00	6,00	10	5,58
AKL 150	6"	160 - 169	220	115	3x30	3x30x40	12x14	M10 (8.8)	20,00	6,00	10	5,93
AKL 180	170-180	170 - 180	229	120	3x30	3x30x40	12x14	M10 (8.8)	20,00	6,00	20	11,76
AKL 190	202-214	202 - 214	264	137	3x30	3x30x40	12x14	M10 (8.8)	20,00	6,00	20	13,30
AKL 200	8"	219 - 230	279	145	4x30	4x30x40	12x14	M10 (8.8)	20,00	6,00	15	10,46
AKL 240	245-255	245 - 255	310	170	4x30	4x30x40	12x14	M10 (8.8)	20,00	6,00	15	15,00
AKL 250	10"	273 - 283	335	173	4x30	4x30x40	12x14	M10 (8.8)	20,00	6,00	15	12,77
AKL 300	12"	317 - 333	400	184	4x40	4x40x40	12,5x23	M12 (8.8)	35,00	11,70	10	16,50
AKL 350	14"	349 - 365	432	221	4x40	4x40x40	12,5x23	M12 (8.8)	35,00	11,70	8	14,30
AKL 380	385-395	385 - 395	505	253	5x50	5x50x60	17x25	M16 (8.8)	37,00	13,00	5	16,10
AKL 400	16"	398 - 414	537	265	5x50	5x50x60	17x25	M16 (8.8)	37,00	13,00	5	17,81
AKL 450	18"	450 - 466	590	301	5x50	5x50x60	17x25	M16 (8.8)	37,00	13,00	5	19,65
AKL 500	20"	501 - 517	645	325	5x50	5x50x60	17x25	M16 (8.8)	37,00	13,00	4	16,60

Heavy Duty Pipe Clamps With Combi Nut

Издържливи скоби за тръби с комбинирана гайка



AKS

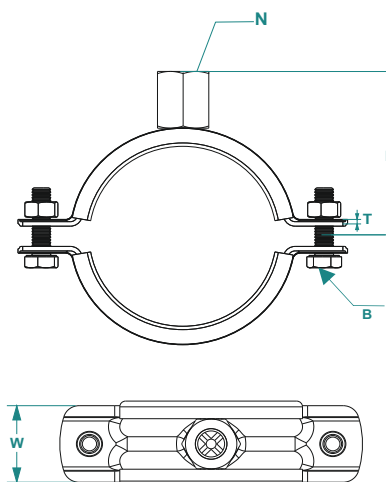

Material
Steel
Standard Finish
Zinc Plated
Hardness of Rubber Lining
55 \pm 5 Shore A
Isolation Rubber
Standard TPE, on request EPDM
Temperature Resistance
-50 $^{\circ}$ C / +110 $^{\circ}$ C

AKS

CODE	SIZE	CLAMPING RANGE (mm)	LENGTH (L) (mm)	HEIGHT (H) (mm)	SHEET (TxW) (mm)	NUT (N) (Metric)	BOLT (B) (Metric)	BREAKING LOAD (kN)	RECOMMENDED LOAD (kN)	QUANTITY PER BOX (Pcs)	WEIGHT (AVERAGE KG) (kg)
AKS 008	1/4"	12 - 17	75	34	2x25	M10 / M12	M8 (6.8)	10.00	2.75	50	6.77
AKS 015	1/2"	21 - 28	81	38	2x25	M10 / M12	M8 (6.8)	10.00	2.75	50	7.42
AKS 020	3/4"	25 - 32	87	41	2x25	M10 / M12	M8 (6.8)	10.00	2.75	50	7.84
AKS 025	1"	33 - 40	94	44.5	2x25	M10 / M12	M8 (6.8)	10.00	2.75	50	8.41
AKS 032	1 1/4"	41 - 48	103	49	2x25	M10 / M12	M8 (6.8)	10.00	2.75	50	8.96
AKS 040	1 1/2"	48 - 53	111	52.5	2x25	M10 / M12	M8 (6.8)	10.00	2.75	50	9.64
AKS 047	53-59	53 - 59	120	56.5	2x25	M10 / M12	M8 (6.8)	10.00	2.75	40	8.10
AKS 050	2"	60 - 69	125	59	2x25	M10 / M12	M8 (6.8)	10.00	2.75	40	8.51
AKS 060	67-75	67 - 75	134	63	2x25	M10 / M12	M8 (6.8)	10.00	2.75	40	8.97
AKS 065	2 1/2"	75 - 81	141	67	2x25	M10 / M12	M8 (6.8)	10.00	2.75	30	7.36
AKS 075	83-91	83 - 91	149	71	2x25	M10 / M12	M8 (6.8)	10.00	2.75	30	7.58
AKS 080	3"	87 - 95	154	73	2x25	M10 / M12	M8 (6.8)	10.00	2.75	30	7.97
AKS 085	95-104	95 - 104	161	77	2x25	M10 / M12	M8 (6.8)	10.00	2.75	30	8.13
AKS 095	102-112	102 - 112	169	81	2,5x30	M10 / M12	M8 (6.8)	14.00	3.75	30	11.52
AKS 100	4"	109 - 119	178	86.6	2,5x30	M10 / M12	M8 (6.8)	14.00	3.75	30	12.29
AKS 110	122-138	122 - 138	192	99.1	3x30	M12 / M16	M10 (8.8)	20.00	6.00	20	11.88
AKS 120	128-141	128 - 141	197	101.6	3x30	M12 / M16	M10 (8.8)	20.00	6.00	10	6.18
AKS 125	5"	136 - 147	204	105.1	3x30	M12 / M16	M10 (8.8)	20.00	6.00	10	6.61
AKS 140	153-164	153 - 164	220	113.1	3x30	M12 / M16	M10 (8.8)	20.00	6.00	10	6.77
AKS 150	6"	164 - 174	229	117.6	3x30	M12 / M16	M10 (8.8)	20.00	6.00	10	7.01
AKS 180	196-209	196 - 209	264	135.1	3x30	M12 / M16	M10 (8.8)	20.00	6.00	20	15.67
AKS 200	8"	214 - 226	279	142.6	4x30	M12 / M16	M10 (8.8)	20.00	6.00	15	15.53
AKS 240	240-250	240 - 250	310	157	4x30	M12 / M16	M10 (8.8)	20.00	6.00	15	17.18
AKS 250	10"	266 - 274	335	170.8	4x30	M12 / M16	M10 (8.8)	20.00	6.00	15	18.35
AKS 300	12"	308 - 324	400	193.8	4x40	M12 / M16	M12 (8.8)	35.00	11.70	10	18.47
AKS 350	14"	340 - 356	432	209.8	4x40	M12 / M16	M12 (8.8)	35.00	11.70	10	20.05
AKS 380	380-390	380 - 390	505	223	5x50	M12 / M16	M16 (8.8)	37.00	13.00	5	17.81
AKS 400	16"	393 - 409	537	239	5x50	M12 / M16	M16 (8.8)	37.00	13.00	5	18.65
AKS 450	18"	444 - 460	590	269.5	5x50	M12 / M16	M16 (8.8)	37.00	13.00	5	20.50
AKS 500	20"	497 - 512	645	295	5x50	M12 / M16	M16 (8.8)	37.00	13.00	4	18.12

Heavy Duty Pipe Clamps With Combi Nut (Without Rubber)

Издръжливи скоби за тръби с комбинирана гайка (без гума)

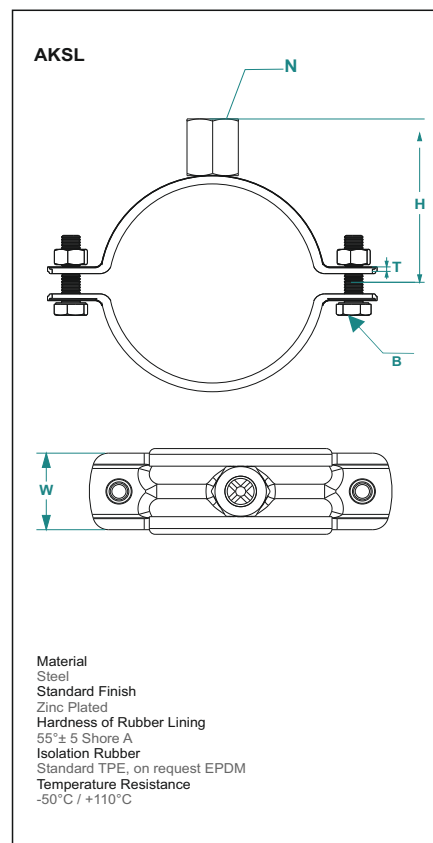

AKSL

CODE	SIZE	RANGE CLAMPING (mm)	LENGTH (L) (mm)	HEIGHT (H) (mm)	SHEET (TxW) (mm)	NUT (N) (Metric)	BOLT (B) (Metric)	BREAKING LOAD (kN)	RECOMMENDED LOAD (kN)	QUANTITY PER BOX (Pcs)	WEIGHT (AVERAGE KG) (kg)
AKSL 015	1/2"	18- 23	75	34	2x25	M10 / M12	M8 (6.8)	10.00	2.75	50	6.10
AKSL 020	3/4"	26 -31	81	38	2x25	M10 / M12	M8 (6.8)	10.00	2.75	50	6.60
AKSL 025	1"	31 - 37	87	41	2x25	M10 / M12	M8 (6.8)	10.00	2.75	50	6.90
AKSL 032	1 1/4"	38 - 44	94	44.5	2x25	M10 / M12	M8 (6.8)	10.00	2.75	50	7.40
AKSL 040	1 1/2"	46 - 53	103	49	2x25	M10 / M12	M8 (6.8)	10.00	2.75	50	7.80
AKSL 047	54-60	54 - 60	111	52.5	2x25	M10 / M12	M8 (6.8)	10.00	2.75	40	6.72
AKSL 050	2"	60 - 68	120	56.5	2x25	M10 / M12	M8 (6.8)	10.00	2.75	40	6.96
AKSL 060	66-73	66 - 73	125	59	2x25	M10 / M12	M8 (6.8)	10.00	2.75	40	7.32
AKSL 065	2 1/2"	74 - 81	134	63	2x25	M10 / M12	M8 (6.8)	10.00	2.75	30	5.82
AKSL 075	82-88	82 - 88	141	67	2x25	M10 / M12	M8 (6.8)	10.00	2.75	30	6.33
AKSL 080	3"	88 - 97	149	71	2x25	M10 / M12	M8 (6.8)	10.00	2.75	30	6.48
AKSL 085	93-100	93 - 100	154	73	2x25	M10 / M12	M8 (6.8)	10.00	2.75	30	6.81
AKSL 095	101-109	101 - 109	161	77	2x25	M10 / M12	M8 (6.8)	10.00	2.75	30	6.90
AKSL 100	4"	110 - 118	169	81	2,5x30	M10 / M12	M8 (6.8)	14.00	3.75	30	10.02
AKSL 110	116-126	116 - 126	178	86.6	2,5x30	M10 / M12	M8 (6.8)	14.00	3.75	30	10.68
AKSL 120	130-141	130 - 141	192	99.1	3x30	M12 / M16	M10 (8.8)	20.00	6.00	20	5.37
AKSL 125	5"	136 - 145	197	101.6	3x30	M12 / M16	M10 (8.8)	20.00	6.00	10	5.38
AKSL 140	144-154	144 - 154	204	105.1	3x30	M12 / M16	M10 (8.8)	20.00	6.00	10	5.77
AKSL 150	6"	160 - 169	220	113.1	3x30	M12 / M16	M10 (8.8)	20.00	6.00	10	5.87
AKSL 180	10-180	170 - 180	229	117.6	3x30	M12 / M16	M10 (8.8)	20.00	6.00	10	11.86
AKSL 190	202-214	202 - 214	264	135.1	3x30	M12 / M16	M10 (8.8)	20.00	6.00	20	13.56
AKSL 200	8"	219 - 230	279	142.6	4x30	M12 / M16	M10 (8.8)	20.00	6.00	20	13.67
AKSL 240	245-255	245 - 255	310	157	4x30	M12 / M16	M10 (8.8)	20.00	6.00	15	15.15
AKSL 250	10"	273 - 283	335	170.8	4x30	M12 / M16	M10 (8.8)	20.00	6.00	15	16.13
AKSL 300	12"	317 - 333	400	193.8	4x40	M12 / M16	M12 (8.8)	35.00	11.70	10	16.30
AKSL 350	14"	349 - 365	432	209.8	4x40	M12 / M16	M12 (8.8)	35.00	11.70	8	14.23
AKSL 380	385-395	385 - 395	505	223	5x50	M12 / M16	M16 (8.8)	37.00	13.00	5	15.44
AKSL 400	16"	398 - 414	537	239	5x50	M12 / M16	M16 (8.8)	37.00	13.00	5	16.19
AKSL 450	18"	450 - 466	590	269.5	5x50	M12 / M16	M16 (8.8)	37.00	13.00	5	17.75
AKSL 500	20"	201 - 517	645	295	5x50	M12 / M16	M16 (8.8)	37.00	13.00	4	15.65

Pipe Clamps



ЕНЕРДЖИ ГРУП ООД

Heavy Duty Pipe Clamp without Nut, Set

Скоба за тежка тръба без гайка, комплект



ACS pipe clamp includes 4 hex nut, 4 flat washer and 2 dowels

Application

Used with HDPE, Cast Iron, Steel and Wavin pipes.

Package View & Mounting Example



ACS

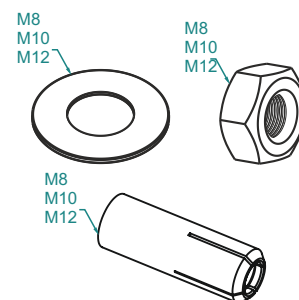
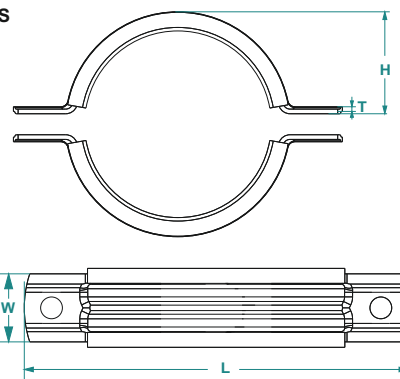

Material

Steel
Standard Finish
Zinc Plated
Hardness of Rubber Lining
55 \pm 5 Shore A
Isolation Rubber
Standard TPE, on request EPDM
Temperature Resistance
-50 $^{\circ}$ C / +110 $^{\circ}$ C

ACS

CODE	SIZE	CLAMPING RANGE (mm)	LENGTH (L) (mm)	HEIGHT (H) (mm)	SHEET (TxW) (mm)	DOWEL 2 PC (metric)	NUT & WASHER 4 PC each (metric)	BREAKING LOAD (kN)	RECOMMENDED LOAD (kN)	QUANTITY PER BOX (Pcs)	WEIGHT (AVERAGE KG) (kg)
ACS 008	1/4"	12 - 17	75	26	2x25	M8x30	M8	10,00	2,75	50	6,00
ACS 015	1/2"	21 - 28	81	30	2x25	M8x30	M8	10,00	2,75	50	6,65
ACS 020	3/4"	25 - 32	87	33	2x25	M8x30	M8	10,00	2,75	50	7,05
ACS 025	1"	33 - 40	94	36,5	2x25	M8x30	M8	10,00	2,75	50	7,65
ACS 032	1 1/4"	41 - 48	103	41	2x25	M8x30	M8	10,00	2,75	50	8,20
ACS 040	1 1/2"	48 - 53	111	44,5	2x25	M8x30	M8	10,00	2,75	50	8,85
ACS 047	53-59	53 - 59	120	48,5	2x25	M8x30	M8	10,00	2,75	40	7,48
ACS 050	2"	60 - 69	125	51	2x25	M8x30	M8	10,00	2,75	40	7,88
ACS 060	67-75	67 - 75	134	55	2x25	M8x30	M8	10,00	2,75	40	8,36
ACS 065	2 1/2"	75 - 81	141	59	2x25	M8x30	M8	10,00	2,75	30	6,90
ACS 075	83-91	83 - 91	149	63	2x25	M8x30	M8	10,00	2,75	30	7,14
ACS 080	3"	87 - 95	154	65	2x25	M8x30	M8	10,00	2,75	30	7,53
ACS 085	95-104	95 - 104	161	69	2x25	M8x30	M8	10,00	2,75	30	7,68
ACS 095	102-112	102 - 112	169	73	2,5x30	M10x40	M10	14,00	3,75	30	12,33
ACS 100	4"	109 - 119	178	78,6	2,5x30	M10x40	M10	14,00	3,75	30	13,11
ACS 110	122-138	122 - 138	192	90,1	3x30	M10x40	M10	20,00	6,00	20	10,56
ACS 120	128-141	128 - 141	197	92,6	3x30	M10x40	M10	20,00	6,00	10	5,50
ACS 125	5"	136 - 147	204	96,1	3x30	M10x40	M10	20,00	6,00	10	5,93
ACS 140	153-164	153 - 164	220	104,1	3x30	M10x40	M10	20,00	6,00	10	6,09
ACS 150	6"	164 - 174	229	108,6	3x30	M10x40	M10	20,00	6,00	10	6,33
ACS 180	196-209	196 - 209	264	126,1	3x30	M10x40	M10	20,00	6,00	20	14,34
ACS 200	8"	214 - 226	279	133,6	4x30	M10x40	M10	20,00	6,00	15	14,54
ACS 240	240-250	240 - 250	310	148	4x30	M10x40	M10	20,00	6,00	15	15,92
ACS 250	10"	266 - 274	335	161,8	4x30	M10x40	M10	20,00	6,00	15	18,56
ACS 300	12"	308 - 324	400	184,8	4x40	M10x40	M10	35,00	11,70	10	18,16
ACS 350	14"	340 - 356	432	200,8	4x40	M10x40	M10	35,00	11,70	10	19,74
ACS 380	380-390	380 - 390	505	214	5x50	M12x50	M12	37,00	13,00	5	17,58
ACS 400	16"	393 - 409	537	230	5x50	M12x50	M12	37,00	13,00	5	18,42
ACS 450	18"	444 - 460	590	260,5	5x50	M12x50	M12	37,00	13,00	5	20,26
ACS 500	20"	497 - 512	645	286	5x50	M12x50	M12	37,00	13,00	4	17,93

Heavy Duty Pipe Clamp without Nut, without Rubber, Set

Скоба за тежка тръба без гайка, без гума, (комплект)



ACLS pipe clamp includes 4 hex nut, 4 flat washer and 2 dowels

Application

Used with HDPE, Cast Iron, Steel and Wavin pipes.

Package View & Mounting Example

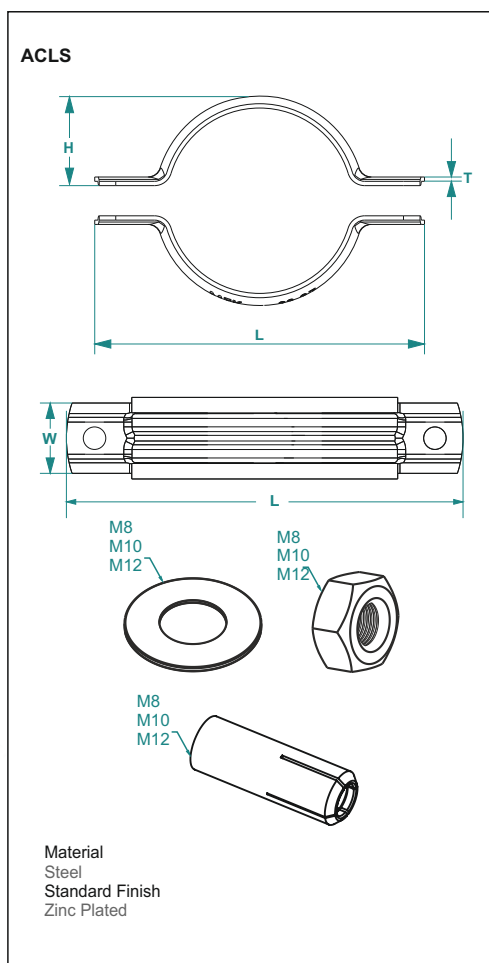

ACLS

CODE	SIZE	CLAMPING RANGE (mm)	LENGTH (L) (mm)	HEIGHT (H) (mm)	SHEET (TxW) (mm)	DOWEL 2 PC (metric)	NUT & WASHER 4 PC each (metric)	BREAKING LOAD (kN)	RECOMMENDED LOAD (kN)	QUANTITY PER BOX (Pcs)	WEIGHT (AVERAGE KG) (kg)
ACLS 015	1/2"	18 - 23	75	26	2x25	M8x30	M8	10,00	2,75	50	5,75
ACLS 020	3/4"	26 - 31	81	30	2x25	M8x30	M8	10,00	2,75	50	6,25
ACLS 025	1"	31 - 37	87	33	2x25	M8x30	M8	10,00	2,75	50	6,60
ACLS 032	1 1/4"	38 - 44	94	36,5	2x25	M8x30	M8	10,00	2,75	50	7,05
ACLS 040	1 1/2"	46 - 53	103	41	2x25	M8x30	M8	10,00	2,75	50	7,45
ACLS 047	54-60	54 - 60	111	44,5	2x25	M8x30	M8	10,00	2,75	40	6,44
ACLS 050	2"	60 - 68	120	48,5	2x25	M8x30	M8	10,00	2,75	40	6,68
ACLS 060	66-73	66 - 73	125	51	2x25	M8x30	M8	10,00	2,75	40	7,04
ACLS 065	2 1/2"	74 - 81	134	55	2x25	M8x30	M8	10,00	2,75	30	5,61
ACLS 075	82-88	82 - 88	141	59	2x25	M8x30	M8	10,00	2,75	30	6,12
ACLS 080	3"	88 - 97	149	63	2x25	M8x30	M8	10,00	2,75	30	6,27
ACLS 085	93-100	93 - 100	154	65	2x25	M8x30	M8	10,00	2,75	30	6,60
ACLS 095	101-109	101 - 109	161	69	2x25	M8x30	M8	10,00	2,75	30	6,69
ACLS 100	4"	110 - 118	169	73	2,5x30	M10x40	M10	14,00	3,75	30	11,07
ACLS 110	116-126	116 - 126	178	78,6	2,5x30	M10x40	M10	14,00	3,75	30	11,73
ACLS 120	130-141	130 - 141	192	90,1	3x30	M10x40	M10	20,00	6,00	10	4,96
ACLS 125	5"	136 - 145	197	92,6	3x30	M10x40	M10	20,00	6,00	10	4,97
ACLS 140	144-154	144 - 154	204	96,1	3x30	M10x40	M10	20,00	6,00	10	5,36
ACLS 150	6"	160 - 169	220	104,1	3x30	M10x40	M10	20,00	6,00	10	5,46
ACLS 180	170-180	170 - 180	229	108,6	3x30	M10x40	M10	20,00	6,00	20	11,04
ACLS 190	202-214	202 - 214	264	126,1	3x30	M10x40	M10	20,00	6,00	20	12,74
ACLS 200	8"	219 - 230	279	133,6	4x30	M10x40	M10	20,00	6,00	15	13,05
ACLS 240	245-255	245 - 255	310	148	4x30	M10x40	M10	20,00	6,00	15	14,27
ACLS 250	10"	273 - 283	335	161,8	4x30	M10x40	M10	20,00	6,00	15	16,71
ACLS 300	12"	317 - 333	400	184,8	4x40	M10x40	M10	35,00	11,70	10	16,24
ACLS 350	14"	349 - 365	432	200,8	4x40	M10x40	M10	35,00	11,70	8	14,18
ACLS 380	385-395	385 - 395	505	214	5x50	M12X50	M12	37,00	13,00	5	15,33
ACLS 400	16"	398 - 414	537	230	5x50	M12X50	M12	37,00	13,00	5	16,08
ACLS 450	18"	450 - 466	590	260,5	5x50	M12X50	M12	37,00	13,00	5	17,64
ACLS 500	20"	501 - 517	645	286	5x50	M12X50	M12	37,00	13,00	4	15,56

Heavy Duty Pipe Clamp with Nut

Издръжлива скоба за тръба с гайка



Application / Uygulama

Used with HDPE, Cast Iron, Steel and Wavin pipes.

Mounting Example

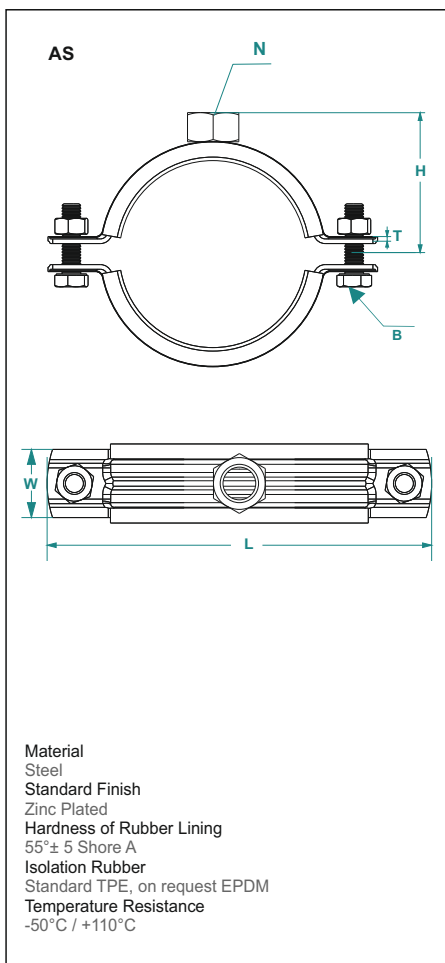

AS

CODE	SIZE	CLAMPING RANGE (mm)	LENGTH (L) (mm)	HEIGHT (H) (mm)	SHEET (TxW) (mm)	NUT (N) (metric)	BOLT (B) (metric)	BREAKING LOAD (kN)	RECOMMENDED LOAD (kN)	QUANTITY PER BOX (Pcs)	WEIGHT (AVERAGE KG) (kg)
AS 008	1/4"	12 - 17	75	26	2x25	M12	M8 (6,8)	10	2,75	50	6,35
AS 015	1/2"	21 - 28	81	30	2x25	M12	M8 (6,8)	10	2,75	50	7,00
AS 020	3/4"	25 - 32	87	33	2x25	M12	M8 (6,8)	10	2,75	50	7,40
AS 025	1"	33 - 40	94	36,5	2x25	M12	M8 (6,8)	10	2,75	50	8,00
AS 032	1 1/4"	41 - 48	103	41	2x25	M12	M8 (6,8)	10	2,75	50	8,55
AS 040	1 1/2"	48 - 53	111	44,5	2x25	M12	M8 (6,8)	10	2,75	50	9,20
AS 047	53-59	53 - 59	120	48,5	2x25	M12	M8 (6,8)	10	2,75	40	7,76
AS 050	2"	60 - 69	125	51	2x25	M12	M8 (6,8)	10	2,75	40	8,16
AS 060	67-75	67 - 75	134	55	2x25	M12	M8 (6,8)	10	2,75	40	8,64
AS 065	2 1/2"	75 - 81	141	59	2x25	M12	M8 (6,8)	10	2,75	30	7,11
AS 075	83-91	83 - 91	149	63	2x25	M12	M8 (6,8)	10	2,75	30	7,32
AS 080	3"	87 - 95	154	65	2x25	M12	M8 (6,8)	10	2,75	30	7,74
AS 085	95-104"	95 - 104	161	69	2x25	M12	M8 (6,8)	10	2,75	30	7,89
AS 095	102-112	102 - 112	169	73	2,5x30	M12	M8 (6,8)	14	3,75	30	11,28
AS 100	4"	109 - 119	178	78,6	2,5x30	M12	M8 (6,8)	14	3,75	30	12,06
AS 110	122-138	122 - 138	192	90,1	3x30	M16	M10 (8,8)	20	6	20	11,38
AS 120	128-141	128 - 141	197	92,6	3x30	M16	M10 (8,8)	20	6	10	5,91
AS 125	5"	136 - 147	204	96,1	3x30	M16	M10 (8,8)	20	6	10	6,34
AS 140	153-164	153 - 164	220	104,1	3x30	M16	M10 (8,8)	20	6	10	6,50
AS 150	6"	164 - 174	229	108,6	3x30	M16	M10 (8,8)	20	6	10	6,74
AS 180	196-209	196 - 209	264	126,1	3x30	M16	M10 (8,8)	20	6	20	15,16
AS 200	8"	214 - 226	279	133,6	4x30	M16	M10 (8,8)	20	6	15	15,15
AS 240	240-250	240 - 250	310	148	4x30	M16	M10 (8,8)	20	6	15	16,80
AS 250	10"	266 - 274	335	161,8	4x30	M16	M10 (8,8)	20	6	15	17,97
AS 300	12"	308 - 324	400	184,8	4x40	M16	M12 (8,8)	35	11,7	10	18,22
AS 350	14"	340 - 356	432	200,8	4x40	M16	M12 (8,8)	35	11,7	10	19,80
AS 380	380-390	380 - 390	505	214	5x50	M16	M16 (8,8)	37	13	5	17,69
AS 400	16"	393 - 409	537	230	5x50	M16	M16 (8,8)	37	13	5	18,53
AS 450	18"	444 - 460	590	260,5	5x50	M16	M16 (8,8)	37	13	5	20,37
AS 500	20"	497 - 512	645	286	5x50	M16	M16 (8,8)	37	13	4	18,02

Heavy Duty Pipe Clamp with Nut without Rubber

Издържлива скоба за тръба с гайка без гума



Application

Used with HDPE, Cast Iron, Steel and Wavin pipes.

Mounting Example



ASL

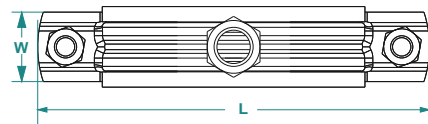
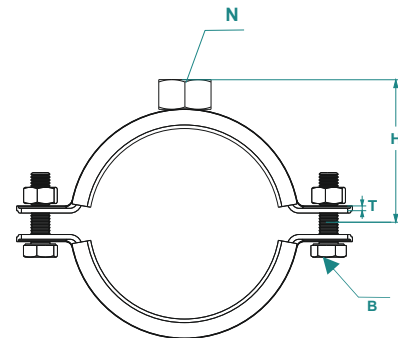

Material
Steel
Standard Finish
Zinc Plated

ASL

CODE	SIZE	CLAMPING RANGE (mm)	LENGTH (L) (mm)	HEIGHT (H) (mm)	SHEET (TxW) (mm)	NUT (N) (metric)	BOLT (B) (metric)	BREAKING LOAD (kN)	RECOMMENDED LOAD (kN)	QUANTITY PER BOX (Pcs)	WEIGHT (AVERAGE KG) (kg)
ASL 015	1/2"	18 - 23	75	26	2x25	M12	M8 (6.8)	10,00	2,75	50	6,10
ASL 020	3/4"	26 - 31	81	30	2x25	M12	M8 (6.8)	10,00	2,75	50	6,60
ASL 025	1"	31 - 37	87	33	2x25	M12	M8 (6.8)	10,00	2,75	50	6,90
ASL 032	1 1/4"	38 - 44	94	36,5	2x25	M12	M8 (6.8)	10,00	2,75	50	7,40
ASL 040	1 1/2"	46 - 53	103	41	2x25	M12	M8 (6.8)	10,00	2,75	50	7,80
ASL 047	54-60	54 - 60	111	44,5	2x25	M12	M8 (6.8)	10,00	2,75	40	6,72
ASL 050	2"	60 - 68	120	48,5	2x25	M12	M8 (6.8)	10,00	2,75	40	6,96
ASL 060	66-73	66 - 73	125	51	2x25	M12	M8 (6.8)	10,00	2,75	40	7,32
ASL 065	2 1/2"	74 - 81	134	55	2x25	M12	M8 (6.8)	10,00	2,75	30	5,82
ASL 075	82-88	82 - 88	141	59	2x25	M12	M8 (6.8)	10,00	2,75	30	6,33
ASL 080	3"	88 - 97	149	63	2x25	M12	M8 (6.8)	10,00	2,75	30	6,48
ASL 085	93-100	93 - 100	154	65	2x25	M12	M8 (6.8)	10,00	2,75	30	6,81
ASL 095	101-109	101 - 109	161	69	2x25	M12	M8 (6.8)	10,00	2,75	30	6,90
ASL 100	4"	110 - 118	169	73	2,5x30	M12	M8 (6.8)	14,00	3,75	30	10,02
ASL 110	116-126	116 - 126	178	78,6	2,5x30	M12	M8 (6.8)	14,00	3,75	30	10,68
ASL 120	130-141	130 - 141	192	90,1	3x30	M16	M10 (8.8)	20,00	6,00	10	5,37
ASL 125	5"	136 - 145	197	92,6	3x30	M16	M10 (8.8)	20,00	6,00	10	5,38
ASL 140	144-154	144 - 154	204	96,1	3x30	M16	M10 (8.8)	20,00	6,00	10	5,77
ASL 150	6"	160 - 169	220	104,1	3x30	M16	M10 (8.8)	20,00	6,00	10	5,87
ASL 180	170-180	170 - 180	229	108,6	3x30	M16	M10 (8.8)	20,00	6,00	20	11,86
ASL 190	202-214	202 - 214	264	126,1	3x30	M16	M10 (8.8)	20,00	6,00	20	13,56
ASL 200	8"	219 - 230	279	133,6	4x30	M16	M10 (8.8)	20,00	6,00	15	13,67
ASL 240	245-255	245 - 255	310	148	4x30	M16	M10 (8.8)	20,00	6,00	15	15,15
ASL 250	10"	273 - 283	335	161,8	4x30	M16	M10 (8.8)	20,00	6,00	15	16,13
ASL 300	12"	317 - 333	400	184,8	4x40	M16	M12 (8.8)	35,00	11,70	10	16,30
ASL 350	14"	349 - 365	432	200,8	4x40	M16	M12 (8.8)	35,00	11,70	8	14,23
ASL 380	385-395	385 - 395	505	214	5x50	M16	M16 (8.8)	37,00	13,00	5	15,44
ASL 400	16"	398 - 414	537	230	5x50	M16	M16 (8.8)	37,00	13,00	5	16,19
ASL 450	18"	450 - 466	590	260,5	5x50	M16	M16 (8.8)	37,00	13,00	5	17,75
ASL 500	20"	501 - 517	645	286	5x50	M16	M16 (8.8)	37,00	13,00	4	15,65

Pipe Clamps



ЕНЕРДЖИ ГРУП ООД

Silent Pipe Clamps With Nut

Безшумни тръбни скоби с гайка



Material
Steel
Standard Finish
Zinc Plated
Hardness of Rubber Lining
55 \pm 5 Shore A
Isolation Rubber
Standard TPE, on request EPDM
Temperature Resistance
-50 $^{\circ}$ C / +110 $^{\circ}$ C

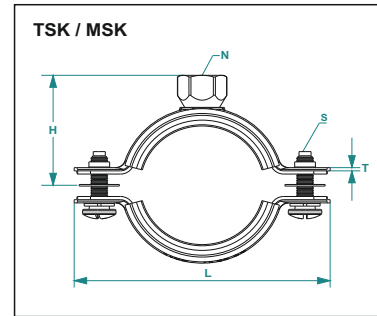

Orange		Blue		SIZE	CLAMPING RANGE (mm)	LENGTH (L) (mm)	HEIGHT (H) (mm)	SHEET (TxW) (mm)	SCREW (S) (metric)	NUT (N) (metric)	BREAKING LOAD (kN)	RECOMMENDED LOAD (kN)	QUANTITY PER BOX (Pcs)	WEIGHT (AVERAGE KG) (kg)
CODE	CODE	CODE	CODE											
TSK 050	MSK 050	Ø50	49-51	105	45,5	1,2x20	M5x18	M8	4,8	1,6	75	7,13		
TSK 075	MSK 075	Ø75	70-76	134	60	1,5x25	M6x30	M10	6,9	2,3	40	7,20		
TSK 110	MSK 110	Ø110	106-114	170	78	1,5x25	M6x30	M10	6,9	2,3	30	7,05		
TSK 125	MSK 125	Ø125	124-130	184	84,5	2X25	M6x35	M10	7,8	2,6	30	9,15		
TSK 160	MSK 160	Ø160	155-162	222	103,5	2X25	M6x30	M10	7,8	2,6	20	7,68		
TSK 200	MSK 200	Ø200	191-200	257	121	2X25	M6x30	M12	7,8	2,6	15	6,74		

Silent Pipe Clamps Without Nut

Безшумни тръбни скоби без гайка



Material
Steel
Standard Finish
Zinc Plated
Hardness of Rubber Lining
55 \pm 5 Shore A
Isolation Rubber
Standard TPE, on request EPDM
Temperature Resistance
-50 $^{\circ}$ C / +110 $^{\circ}$ C

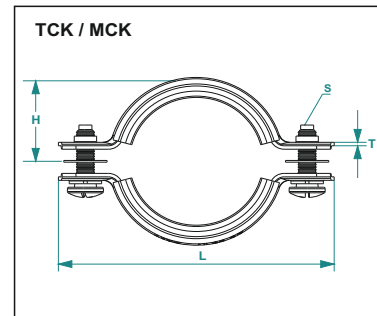

Orange		Blue		SIZE	CLAMPING RANGE (mm)	LENGTH (L) (mm)	HEIGHT (H) (mm)	SHEET (TxW) (mm)	SCREW (S) (metric)	BREAKING LOAD (kN)	RECOMMENDED LOAD (kN)	QUANTITY PER BOX (Pcs)	WEIGHT (AVERAGE KG) (kg)
CODE	CODE	CODE	CODE										
TCK 050	MCK 050	Ø50	49-51	105	35,5	1,2x20	M5x18	4,8	1,6	75	6,60		
TCK 075	MCK 075	Ø75	70-76	134	48	1,5x25	M6x30	6,9	2,3	40	6,60		
TCK 110	MCK 110	Ø110	106-114	170	66	1,5x25	M6x30	6,9	2,3	30	6,60		
TCK 125	MCK 125	Ø125	124-130	184	72,5	2X25	M6x35	7,8	2,6	30	8,73		
TCK 160	MCK 160	Ø160	155-162	222	91,5	2X25	M6x30	7,8	2,6	20	7,40		
TCK 200	MCK 200	Ø200	191-200	257	109	2X25	M6x30	7,8	2,6	15	6,47		

Silent Pipe Clamps With Triphone

Безшумни скоби за тръби с трифон

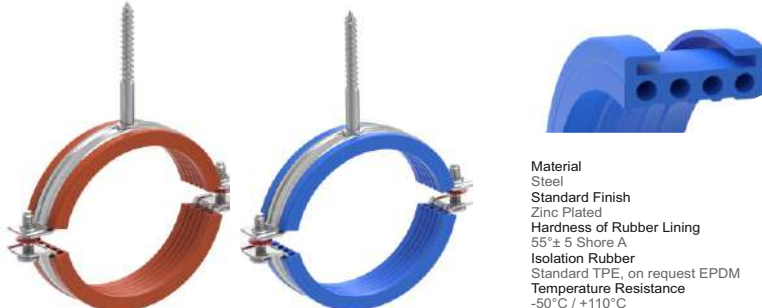

Material
Steel
Standard Finish
Zinc Plated
Hardness of Rubber Lining
55 \pm 5 Shore A
Isolation Rubber
Standard TPE, on request EPDM
Temperature Resistance
-50 $^{\circ}$ C / +110 $^{\circ}$ C

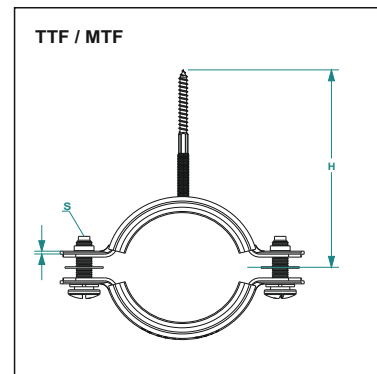

Orange		Blue		SIZE	CLAMPING RANGE (mm)	LENGTH (L) (mm)	HEIGHT (H) (mm)	SHEET (TxW) (mm)	SCREW (S) (metric)	COACH SCREW (CS) (mm)	BREAKING LOAD (kN)	RECOMMENDED LOAD (kN)	QUANTITY PER BOX (Pcs)	WEIGHT (AVERAGE KG) (kg)
CODE	CODE	CODE	CODE											
TTF 050	MTF 050	Ø50	49-51	105	35,5	1,2x20	M5x18	Ø7x70	4,8	1,6	75	6,60		
TTF 075	MTF 075	Ø75	70-76	134	48	1,5x25	M6x30	Ø7x70	6,9	2,3	40	6,60		
TTF 110	MTF 110	Ø110	106-114	170	66	1,5x25	M6x30	Ø7x70	6,9	2,3	30	6,60		
TTF 125	MTF 125	Ø125	124-130	184	72,5	2X25	M6x35	Ø7x70	7,8	2,6	30	8,73		
TTF 160	MTF 160	Ø160	155-162	222	91,5	2X25	M6x30	Ø7x70	7,8	2,6	20	7,40		
TTF 200	MTF 200	Ø200	191-200	257	109	2X25	M6x30	Ø7x70	7,8	2,6	15	6,47		

Pipe Clamps



ЕНЕРДЖИ ГРУП ООД

Silent Pipe Clamps With Nuts

Безшумни тръбни скоби с гайки



Material
Steel
Standard Finish
Zinc Plated
Hardness of Rubber Lining
55°± 5 Shore A
Isolation Rubber
Standard TPE, on request EPDM
Temperature Resistance
-50°C / +110°C

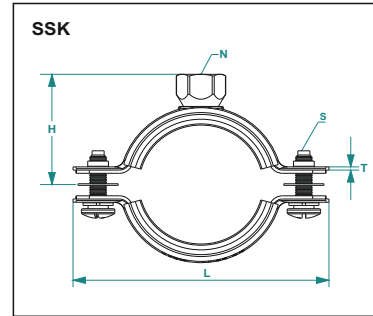

CODE	SIZE	CLAMPING RANGE (mm)	LENGTH (L) (mm)	HEIGHT (H) (mm)	SHEET (TxW) (mm)	SCREW (S) (metric)	NUT (N) (metric)	BREAKING LOAD (kN)	RECOMMENDED LOAD (kN)	QUANTITY PER BOX (Pcs)	WEIGHT (AVERAGE KG) (kg)
SSK 050	Ø50	49-51	105	45,5	1,2x20	M5x18	M8	4,8	1,6	75	7,13
SSK 075	Ø75	70-76	134	60	1,5x25	M6x30	M10	6,9	2,3	40	7,20
SSK 110	Ø110	106-114	170	78	1,5x25	M6x30	M10	6,9	2,3	30	7,05
SSK 125	Ø125	124-130	184	84,5	2X25	M6x35	M10	7,8	2,6	30	9,15
SSK 160	Ø160	155-162	222	103,5	2X25	M6x30	M10	7,8	2,6	20	7,68
SSK 200	Ø200	191-200	257	121	2X25	M6x30	M12	7,8	2,6	15	6,74

Silent Pipe Clamp Without Nut (Black)

Безшумна тръбна скоба без гайка (черна)



Material
Steel
Standard Finish
Zinc Plated
Hardness of Rubber Lining
55°± 5 Shore A
Isolation Rubber
Standard TPE, on request EPDM
Temperature Resistance
-50°C / +110°C

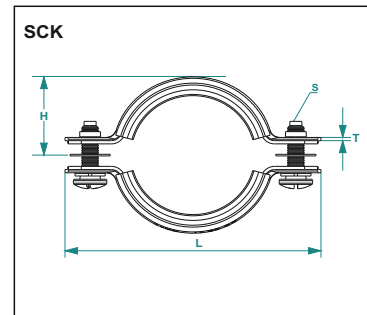

CODE	SIZE	CLAMPING RANGE (mm)	LENGTH (L) (mm)	HEIGHT (H) (mm)	SHEET (TxW) (mm)	SCREW (S) (metric)	BREAKING LOAD (kN)	RECOMMENDED LOAD (kN)	QUANTITY PER BOX (Pcs)	WEIGHT (AVERAGE KG) (kg)
SCK 050	Ø50	49-51	105	35,5	1,2x20	M5x18	4,8	1,6	75	6,60
SCK 075	Ø75	70-76	134	48	1,5x25	M6x30	6,9	2,3	40	6,60
SCK 110	Ø110	106-114	170	66	1,5x25	M6x30	6,9	2,3	30	6,60
SCK 125	Ø125	124-130	184	72,5	2X25	M6x35	7,8	2,6	30	8,73
SCK 160	Ø160	155-162	222	91,5	2X25	M6x30	7,8	2,6	20	7,40
SCK 200	Ø200	191-200	257	109	2X25	M6x30	7,8	2,6	15	6,47

Silent Pipe Clamps With Triphone (Black)

Безшумни скоби за тръби с трифон (черни)



Material
Steel
Standard Finish
Zinc Plated
Hardness of Rubber Lining
55°± 5 Shore A
Isolation Rubber
Standard TPE, on request EPDM
Temperature Resistance
-50°C / +110°C

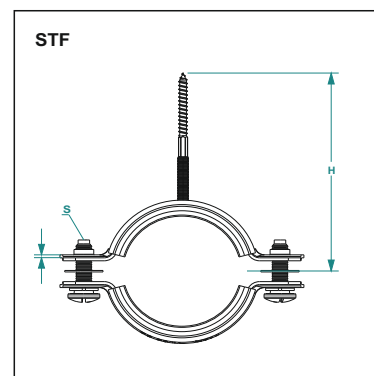

CODE	SIZE	CLAMPING RANGE (mm)	LENGTH (L) (mm)	HEIGHT (H) (mm)	SHEET (TxW) (mm)	SCREW (S) (metric)	COACH SCREW (CS) (metric)	BREAKING LOAD (kN)	RECOMMENDED LOAD (kN)	QUANTITY PER BOX (Pcs)	WEIGHT (AVERAGE KG) (kg)
STF 050	Ø50	49-51	105	105	1,2x20	M5x18	Ø7x70	4,8	1,6	75	7,13
STF 075	Ø75	70-76	134	118	1,5x25	M6x30	Ø7x70	6,9	2,3	40	7,20
STF 110	Ø110	106-114	170	136	1,5x25	M6x30	Ø7x70	6,9	2,3	30	7,05
STF 125	Ø125	124-130	190	142,5	2X25	M6x35	Ø7x70	7,8	2,6	30	9,15
STF 160	Ø160	155-162	222	161,5	2X25	M6x30	Ø7x70	7,8	2,6	20	7,68
STF 200	Ø200	191-200	257	179	2X25	M6x30	Ø7x70	7,8	2,6	15	6,74

Sprinkler Pipe Clamp

Скоба за тръба за спринклер



Application

Used with Fire protection pipes. Designed for suspending pipes allowing for vertical adjustment. The clamp should only be used for horizontal pipe hanging. Loads are complied with NFPA standards.

Mounting Example

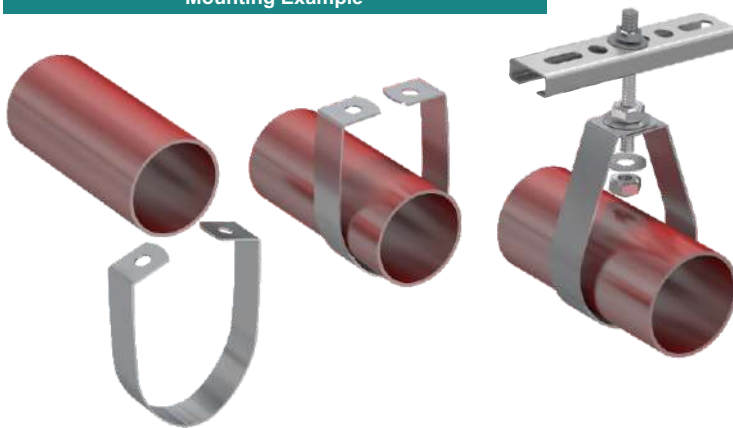

SPR

Material
Steel
Standard Finish
Zinc Plated

SPR

CODE	SIZE	DIAMETER (ØD) (mm)	HEIGHT 1 (H1) (mm)	HEIGHT 2 (H2) (mm)	SHEET (TxW) (mm)	HOLE DIA. ØD (mm)	BREAKING LOAD (kN)	RECOMMENDED LOAD (kN)	QUANTITY PER BOX (pc)	WEIGHT (AVERAGE KG) (kg)
SPR 015	1/2"	28	36,5	51,5	1x25	10,5	6	1,5	150	5,25
SPR 020	3/4"	30	37,5	53,5	1x25	10,5	6	1,5	125	4,50
SPR 025	1"	36	46,5	65,5	1x25	10,5	6	1,5	100	4,20
SPR 032	1 1/4"	46	55,7	79,9	1,2x25	10,5	11	1,5	75	4,50
SPR 040	1 1/2"	52	58,7	85,9	1,2x25	10,5	11	1,5	60	3,84
SPR 050	2"	66	65,7	99,9	1,2x25	10,5	11	1,5	50	3,70
SPR 065	2 1/2"	78	75,5	116	1,5x25	10,5	16	3,9	35	3,71
SPR 080	3"	92	84,5	132	1,5x25	10,5	16	3,9	25	3,05
SPR 100	4"	116	107,5	167,5	2x25	10,5	19	3,9	30	5,97
SPR 125	5"	142	126,5	200	2,5x25	13	22	7,5	30	8,85
SPR 150	6"	170	150,5	238	2,5x25	13	22	7,5	30	10,32
SPR 200	8"	222	197,5	311,5	3x30	17	30	13	10	6,79
SPR 250	10"	275	244	384,5	3x30	17	30	13	15	11,91
SPR 300	12"	324	310	470	3x30	17	30	13	10	9,34

Sprinkler Pipe Clamp Long

Скоба за спринклерна тръба (дълга)



Application

Used with Fire protection pipes. Designed for suspending pipes allowing for vertical adjustment. The clamp should only be used for horizontal pipe hanging. Loads are complied with NFPA standards.

Mounting Example

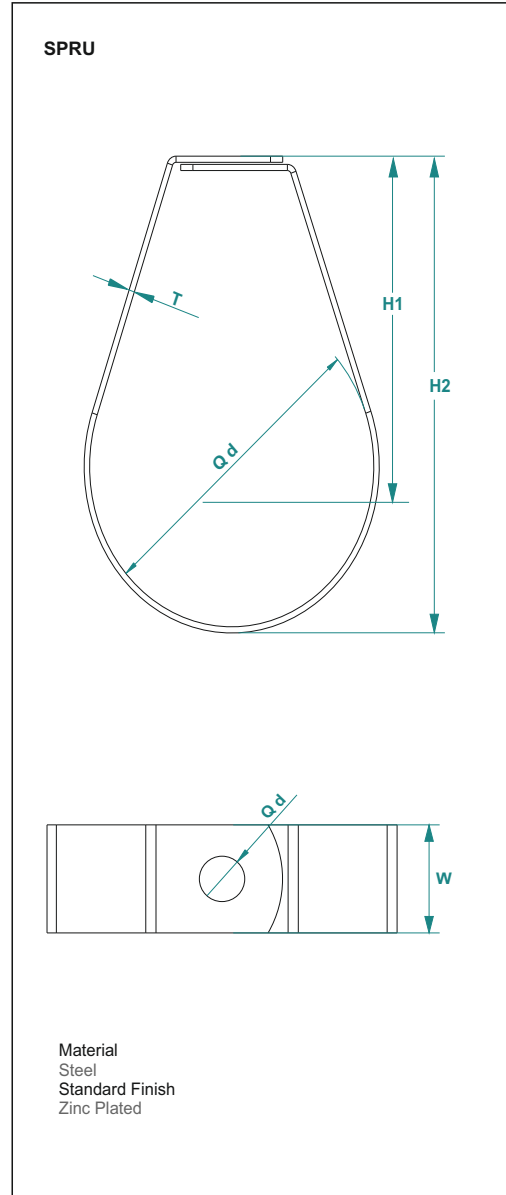
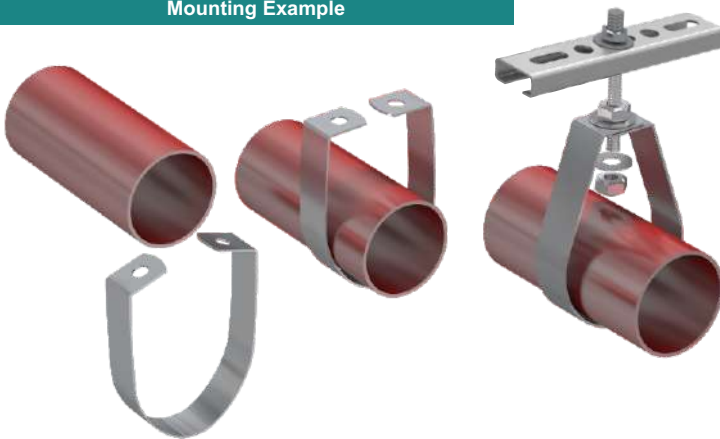

SPRU

CODE	SIZE	DIAMETER (ØD) (mm)	HEIGHT 1 (H1) (mm)	HEIGHT 2 (H2) (mm)	SHEET (TxW) (mm)	HOLE DIA. ØD (mm)	BREAKING LOAD (kN)	RECOMMENDED LOAD (kN)	QUANTITY PER BOX (Pc)	WEIGHT (AVERAGE KG) (kg)
SPRU 015	1/2"	28	48	63,5	1,5x25	10,5	1,5	1,5	100	6,10
SPRU 020	3/4"	30	50	66,5	1,5x25	10,5	1,5	1,5	100	6,40
SPRU 025	1"	36	59	78,5	1,5x25	10,5	1,5	1,5	75	5,40
SPRU 032	1 1/4"	46	63	87,5	1,5x25	10,5	1,5	1,5	50	4,25
SPRU 040	1 1/2"	52	66	93,5	1,5x25	10,5	1,5	1,5	50	4,50
SPRU 050	2"	66	72	106,5	1,5x25	10,5	1,5	1,5	40	4,16
SPRU 065	2 1/2"	78	94	135,5	2,5x25	10,5	3,9	3,9	30	6,06
SPRU 080	3"	92	101	149,5	2,5x25	10,5	3,9	3,9	25	5,83
SPRU 100	4"	116	122	182,5	2,5x25	10,5	3,9	3,9	30	8,13
SPRU 125	5"	142	151,5	225,5	3x25	13	7,5	7,5	25	9,73
SPRU 150	6"	170	176,5	264,5	3x25	13	7,5	7,5	20	8,96
SPRU 200	8"	222	226,5	340,5	3x40	17	13	13	10	9,67
SPRU 250	10"	275	285,5	426	3x40	17	13	13	10	12,23

Sprinkler Pipe Clamp with Nut

Скоба за тръба на спринклер с гайка



SPRS pipe clamp includes rivet nut.

Application

Used with Fire protection pipes. Designed for suspending pipes allowing for vertical adjustment. The clamp should only be used for horizontal pipe hanging. Loads are complied with NFPA standards.

Mounting Example

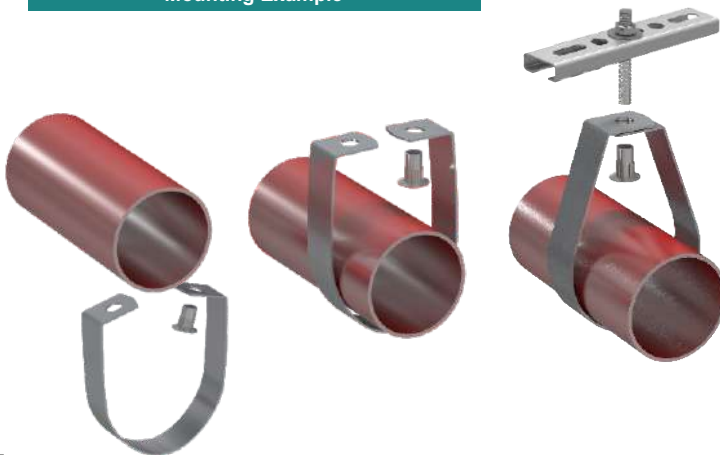

SPRS

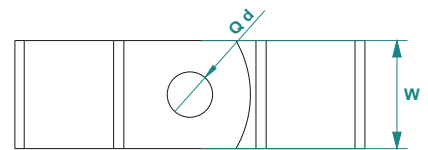
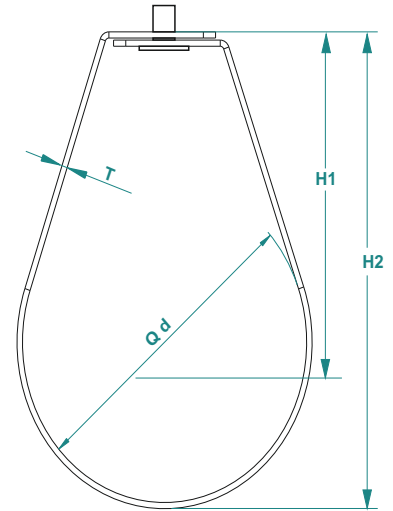

Material
Steel
Standard Finish
Zinc Plated

SPRS

CODE	SIZE	DIAMETER (ØD) (mm)	HEIGHT 1 (H1) (mm)	HEIGHT 2 (H2) (mm)	SHEET (TxW) (mm)	NUT ØD (metric)	BREAKING LOAD (kN)	RECOMMENDED LOAD (kN)	QUANTITY PER BOX (pc)	WEIGHT (AVERAGE KG) (kg)
SPRS 015	1/2"	28	36,5	51,5	1x25	M10	6,0	1,5	150	6,15
SPRS 020	3/4"	30	37,5	53,5	1x25	M10	6,0	1,5	125	5,25
SPRS 025	1"	36	46,5	65,5	1x25	M10	6,0	1,5	100	4,80
SPRS 032	1 1/4"	46	55,7	79,9	1,2x25	M10	11,0	1,5	75	4,95
SPRS 040	1 1/2"	52	58,7	85,9	1,2x25	M10	11,0	1,5	60	4,20
SPRS 050	2"	66	65,7	99,9	1,2x25	M10	11,0	1,5	50	4,00
SPRS 065	2 1/2"	78	75,5	116	1,5x25	M10	16,0	3,9	35	3,92
SPRS 080	3"	92	84,5	132	1,5x25	M10	16,0	3,9	25	3,20
SPRS 100	4"	116	107,5	167,5	2x25	M10	19,0	3,9	30	6,24
SPRS 125	5"	142	126,5	200	2,5x25	M12	22,0	7,5	30	9,12
SPRS 150	6"	170	150,5	238	2,5x25	M12	22,0	7,5	30	10,59
SPRS 200	8"	222	197,5	311,5	3x30	M12	25,0	13	10	6,96
SPRS 250	10"	275	244	384,5	3x30	M12	25,0	13	15	12,17
SPRS 300	12"	324	310	470	3x30	M12	25,0	13	10	9,51

PVC Pipe Clamp

Скоба за PVC тръби



Application

Used with PVC, PE and HDPE pipes.

Mounting Example



PBK

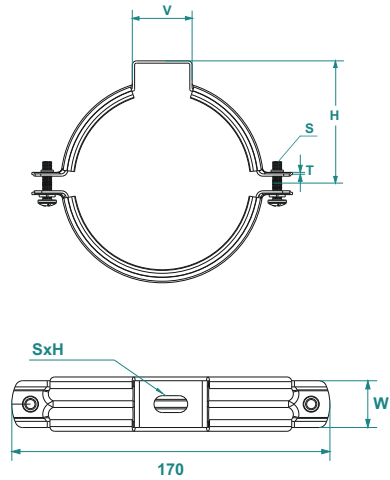

Material

Steel

Standard Finish

Zinc Plated

Hardness of Rubber Lining

55 \pm 5 Shore A

Isolation Rubber

Standard TPE, on request EPDM

Temperature Resistance

-50 $^{\circ}$ C / +110 $^{\circ}$ C

PBK

CODE	SIZE	CLAMPING RANGE	HEIGHT (H)	SHEET (TxW)	CONNECTION ZONE (V)	SLOT HOLE (SxH)	SCREW (S)	BREAKING LOAD (kN)	RECOMMENDED LOAD (kN)	QUANTITY PER BOX (pc)	WEIGHT (AVERAGE KG) (kg)
		(mm)	(mm)	(mm)	(mm)	(mm)	(metric)				
PBK 050	50	48 - 53	45,5	1,2x20	36	9x18	M5	1,2	0,4	75	5,13
PBK 075	75	74 - 81	58,5	1,5x25	36	9x18	M6	1,2	0,4	50	7,51
PBK 100	100	100 - 108	74,5	1,5x25	36	9x18	M6	2	0,7	30	5,93
PBK 125	125	121 - 130	89,5	2x25	36	12,5x20	M6	2	0,7	25	6,86
PBK 150	150	150 -159	103,5	2x25	36	12,5x20	M6	2	0,7	20	6,30
PBK 200	200	193 - 204	134,5	2x25	36	12,5x20	M6	2	0,7	10	4

Ventilation Pipe Clamps

Скоби за вентилационни тръби



M8 Standard Nut

Application
Used with Ventilation pipes.

Mounting Example

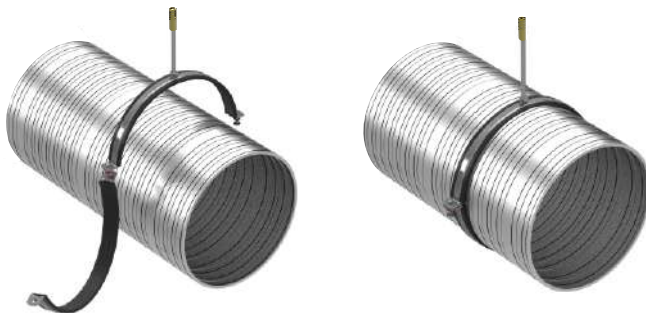

HS

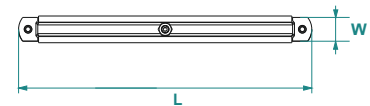
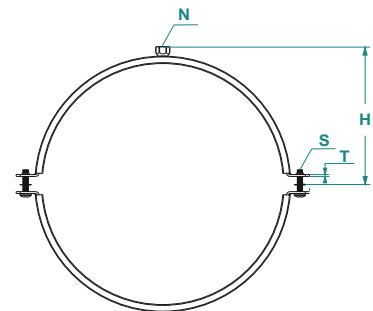

Material
Steel
Standard Finish
Zinc Plated
Hardness of Rubber Lining
55 \pm 5 Shore A
Isolation Rubber
Standard TPE, on request EPDM
Temperature Resistance
-50 $^{\circ}$ C / +110 $^{\circ}$ C

HS

CODE	SIZE	PIPE DIAMETER (\varnothing) (mm)	LENGTH (L) (mm)	HEIGHT (H) (mm)	SHEET (TxW) (mm)	NUT (N) (metric)	SCREW (S) (metric)	QUANTITY (PER BOX) (pc)	WEIGHT (AVERAGE KG)
HS 0071	71	73,4	117	52	1,5x20	M8	M6	40	4,74
HS 0080	80	82,4	126	56,5	1,5x20	M8	M6	35	4,52
HS 0090	90	92,6	136	61,5	1,5x20	M8	M6	35	4,89
HS 0100	100	103,6	147	67	1,5x20	M8	M6	35	5,29
HS 0112	112	115,6	159	73	1,5x20	M8	M6	35	5,74
HS 0125	125	128,6	172	79,5	1,5x20	M8	M6	35	6,21
HS 0140	140	143,6	186	86,5	1,5x20	M8	M6	30	5,81
HS 0150	150	153,6	197	92	1,5x20	M8	M6	30	6,16
HS 0160	160	163,6	209	98	1,5x20	M8	M6	30	6,54
HS 0180	180	183,6	229	108	1,5x20	M8	M6	25	6,02
HS 0200	200	203,6	247	117	1,5x20	M8	M6	20	5,19
HS 0224	224	227,6	280	132	2x25	M8	M6	15	6,45
HS 0250	250	253,6	306	145	2x25	M8	M6	20	9,29
HS 0280	280	284,8	336	160	2x25	M8	M6	20	10,24
HS 0300	300	304,8	357	170,5	2x25	M8	M6	20	10,92
HS 0315	315	319,8	372	178	2x25	M8	M6	20	11,40
HS 0355	355	359,8	412	198	2x25	M8	M6	20	12,68
HS 0400	400	404,8	457	220,5	2x25	M8	M6	20	14,16
HS 0450	450	454,8	507	245,5	2x25	M8	M6	15	11,93
HS 0500	500	504,8	557	270,5	2x25	M8	M6	10	9,23
HS 0560	560	564,8	627	300	2,5x25	M8	M10	10	13,12
HS 0600	600	604,8	667	320	2,5x25	M8	M10	10	13,88
HS 0630	630	636	697	335	2,5x25	M8	M10	10	14,46

Ventilation Pipe Clamp with Nut without Rubber

Скоба за вентилационна тръба с гайка без гума



M8 Standard Nut

Application

Used with Ventilation pipes.

Mounting Example

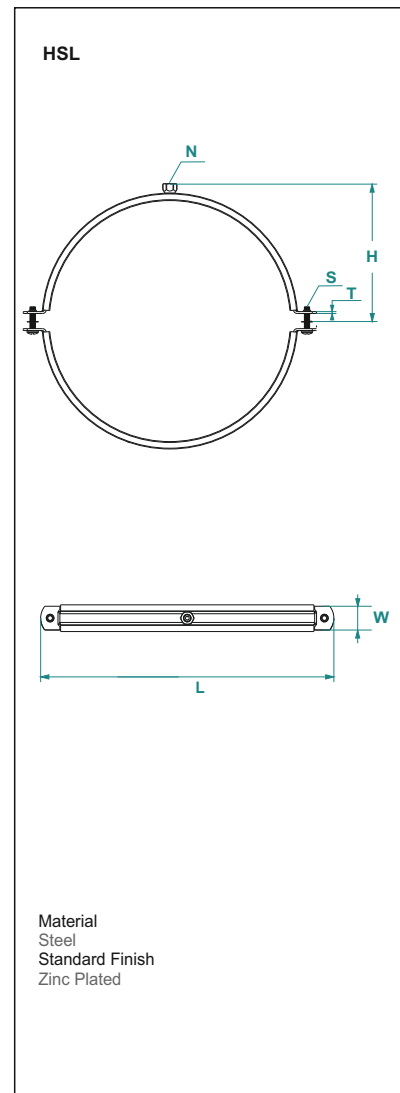
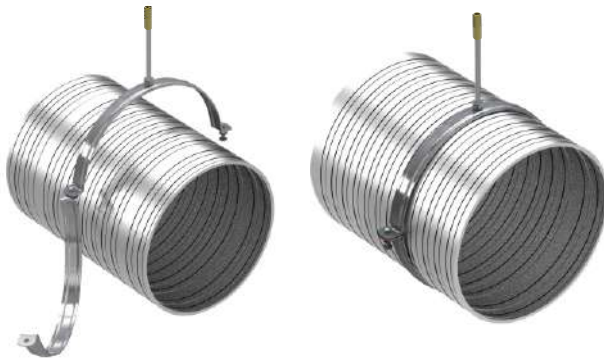

HSL

CODE	SIZE	PIPE DIAMETER (Ø) (mm)	LENGTH (L) (mm)	HEIGHT (H) (mm)	SHEET (TxW) (mm)	NUT (N) (metric)	SCREW (S) (metric)	QUANTITY (PER BOX) (pc)	WEIGHT (AVERAGE KG)
HSL 0071	71	73,4	117	52	1,5x20	M8	M6	40	3,84
HSL 0080	80	82,4	126	56,5	1,5x20	M8	M6	35	3,62
HSL 0090	90	92,6	136	61,5	1,5x20	M8	M6	35	3,88
HSL 0100	100	103,6	147	67	1,5x20	M8	M6	35	4,16
HSL 0112	112	115,6	159	73	1,5x20	M8	M6	35	4,47
HSL 0125	125	128,6	172	79,5	1,5x20	M8	M6	35	4,80
HSL 0140	140	143,6	186	86,5	1,5x20	M8	M6	30	4,46
HSL 0150	150	153,6	197	92	1,5x20	M8	M6	30	4,70
HSL 0160	160	163,6	209	98	1,5x20	M8	M6	30	4,97
HSL 0180	180	183,6	229	108	1,5x20	M8	M6	25	4,55
HSL 0200	200	203,6	247	117	1,5x20	M8	M6	20	3,96
HSL 0224	224	227,6	280	132	2x25	M8	M6	15	5,25
HSL 0250	250	253,6	306	145	2x25	M8	M6	20	7,53
HSL 0280	280	284,8	336	160	2x25	M8	M6	20	8,27
HSL 0300	300	304,8	357	170,5	2x25	M8	M6	20	8,79
HSL 0315	315	319,8	372	178	2x25	M8	M6	20	9,16
HSL 0355	355	359,8	412	198	2x25	M8	M6	20	10,15
HSL 0400	400	404,8	457	220,5	2x25	M8	M6	20	11,30
HSL 0450	450	454,8	507	245,5	2x25	M8	M6	15	9,52
HSL 0500	500	504,8	557	270,5	2x25	M8	M6	10	7,44
HSL 0560	560	564,8	627	300	2,5x25	M8	M10	10	11,13
HSL 0600	600	604,8	667	320	2,5x25	M8	M10	10	11,74
HSL 0630	630	636	697	335	2,5x25	M8	M10	10	12,21

Ventilation Pipe Clamp with Combi Nut

Скоба за вентилационна тръба с комбинирана гайка

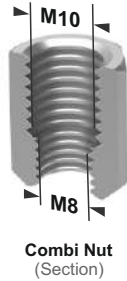

Combi Nut
(Section)

Application
Used with Ventilation pipes.

Mounting Example

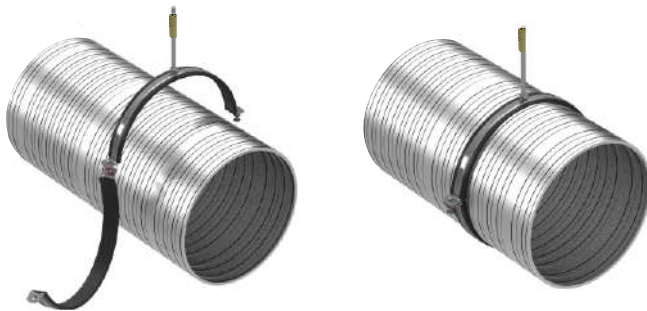

HKS

Material
Steel
Standard Finish
Zinc Plated
Hardness of Rubber Lining
55 \pm 5 Shore A
Isolation Rubber
Standard TPE, on request EPDM
Temperature Resistance
-50 $^{\circ}$ C / +110 $^{\circ}$ C

HKS

CODE	SIZE	PIPE DIAMETER (\varnothing) (mm)	LENGTH (L) (mm)	HEIGHT (H) (mm)	SHEET (TxW) (mm)	NUT (N) (metric)	SCREW (S) (metric)	QUANTITY (PER BOX) (pc)	WEIGHT (AVERAGE KG)
HKS 0071	71	73,4	117	52	1,5x20	M8 / M10	M6	40	5,02
HKS 0080	80	82,4	126	56,5	1,5x20	M8 / M10	M6	35	4,77
HKS 0090	90	92,6	136	61,5	1,5x20	M8 / M10	M6	35	5,14
HKS 0100	100	103,6	147	67	1,5x20	M8 / M10	M6	35	5,54
HKS 0112	112	115,6	159	73	1,5x20	M8 / M10	M6	35	5,99
HKS 0125	125	128,6	172	79,5	1,5x20	M8 / M10	M6	35	6,46
HKS 0140	140	143,6	186	86,5	1,5x20	M8 / M10	M6	30	6,02
HKS 0150	150	153,6	197	92	1,5x20	M8 / M10	M6	30	6,37
HKS 0160	160	163,6	209	98	1,5x20	M8 / M10	M6	30	6,75
HKS 0180	180	183,6	229	108	1,5x20	M8 / M10	M6	25	6,20
HKS 0200	200	203,6	247	117	1,5x20	M8 / M10	M6	20	5,33
HKS 0224	224	227,6	280	132	2x25	M8 / M10	M6	15	6,55
HKS 0250	250	253,6	306	145	2x25	M8 / M10	M6	20	9,43
HKS 0280	280	284,8	336	160	2x25	M8 / M10	M6	20	10,38
HKS 0300	300	304,8	357	170,5	2x25	M8 / M10	M6	20	11,06
HKS 0315	315	319,8	372	178	2x25	M8 / M10	M6	20	11,54
HKS 0355	355	359,8	412	198	2x25	M8 / M10	M6	20	12,82
HKS 0400	400	404,8	457	220,5	2x25	M8 / M10	M6	20	14,30
HKS 0450	450	454,8	507	245,5	2x25	M8 / M10	M6	15	12,04
HKS 0500	500	504,8	557	270,5	2x25	M8 / M10	M6	10	9,30
HKS 0560	560	564,8	627	300	2,5x25	M8 / M10	M10	10	13,19
HKS 0600	600	604,8	667	320	2,5x25	M8 / M10	M10	10	13,95
HKS 0630	630	636	697	335	2,5x25	M8 / M10	M10	10	14,53

Pipe Clamps



ЕНЕРДЖИ ГРУП ООД

Ventilation Pipe Clamp with Combi Nut without Rubber

Скоба за вентилационна тръба с комбинирана гайка / без гума



Combi Nut
(Section)

Application

Used with Ventilation pipes.

Mounting Example

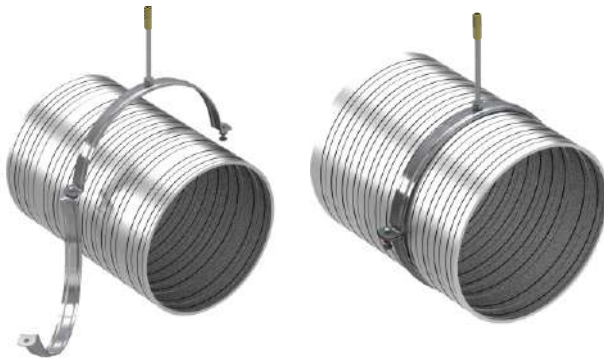

HKSL

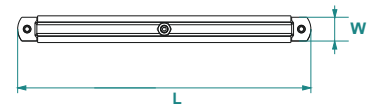
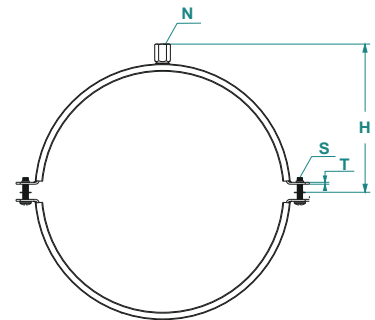

Material
Steel
Standard Finish
Zinc Plated

HKSL

CODE	SIZE	PIPE DIAMETER (\varnothing) (mm)	LENGTH (L) (mm)	HEIGHT (H) (mm)	SHEET (TxW) (mm)	NUT (N) (metric)	SCREW (S) (metric)	QUANTITY (PER BOX) (pc)	WEIGHT (AVERAGE KG)
HKSL 0071	71	73,4	117	52	1,5x20	M8 / M10	M6	40	4,12
HKSL 0080	80	82,4	126	56,5	1,5x20	M8 / M10	M6	35	3,87
HKSL 0090	90	92,6	136	61,5	1,5x20	M8 / M10	M6	35	4,12
HKSL 0100	100	103,6	147	67	1,5x20	M8 / M10	M6	35	4,40
HKSL 0112	112	115,6	159	73	1,5x20	M8 / M10	M6	35	4,71
HKSL 0125	125	128,6	172	79,5	1,5x20	M8 / M10	M6	35	5,04
HKSL 0140	140	143,6	186	86,5	1,5x20	M8 / M10	M6	30	4,67
HKSL 0150	150	153,6	197	92	1,5x20	M8 / M10	M6	30	4,91
HKSL 0160	160	163,6	209	98	1,5x20	M8 / M10	M6	30	5,18
HKSL 0180	180	183,6	229	108	1,5x20	M8 / M10	M6	25	4,73
HKSL 0200	200	203,6	247	117	1,5x20	M8 / M10	M6	20	4,10
HKSL 0224	224	227,6	280	132	2x25	M8 / M10	M6	15	5,36
HKSL 0250	250	253,6	306	145	2x25	M8 / M10	M6	20	7,67
HKSL 0280	280	284,8	336	160	2x25	M8 / M10	M6	20	8,41
HKSL 0300	300	304,8	357	170,5	2x25	M8 / M10	M6	20	8,93
HKSL 0315	315	319,8	372	178	2x25	M8 / M10	M6	20	9,30
HKSL 0355	355	359,8	412	198	2x25	M8 / M10	M6	20	10,29
HKSL 0400	400	404,8	457	220,5	2x25	M8 / M10	M6	20	11,44
HKSL 0450	450	454,8	507	245,5	2x25	M8 / M10	M6	15	9,62
HKSL 0500	500	504,8	557	270,5	2x25	M8 / M10	M6	10	7,51
HKSL 0560	560	564,8	627	300	2,5x25	M8 / M10	M10	10	11,20
HKSL 0600	600	604,8	667	320	2,5x25	M8 / M10	M10	10	11,81
HKSL 0630	630	636	697	335	2,5x25	M8 / M10	M10	10	12,28

Ventilation Pipe Clamp without Nut

Скоба за вентилационна тръба / без гайка



Application

Used with Ventilation pipes.

Mounting Example



HC

Material
 Steel
 Standard Finish
 Zinc Plated
 Hardness of Rubber Lining
 55°± 5 Shore A
 Isolation Rubber
 Standard TPE, on request EPDM
 Temperature Resistance
 -50°C / +110°C

HC

CODE	SIZE	PIPE DIAMETER (Ø) (mm)	LENGTH (L) (mm)	HEIGHT (H) (mm)	SHEET (TxW) (mm)	HOLE SIZE (mm)	ROD (metric)	QUANTITY (PER BOX) (pc)	WEIGHT (AVERAGE KG)
HC 0071	71	73,4	117	37	1,5x20	7x8	M6	40	3,96
HC 0080	80	82,4	126	42	1,5x20	7x8	M6	35	3,85
HC 0090	90	92,6	136	47	1,5x20	7x8	M6	35	4,20
HC 0100	100	103,6	147	52	1,5x20	7x8	M6	35	4,62
HC 0112	112	115,6	159	58	1,5x20	7x8	M6	35	5,04
HC 0125	125	128,6	172	65	1,5x20	7x8	M6	35	5,53
HC 0140	140	143,6	186	72	1,5x20	7x8	M6	30	5,22
HC 0150	150	153,6	197	77	1,5x20	7x8	M6	30	5,58
HC 0160	160	163,6	209	82	1,5x20	7x8	M6	30	5,94
HC 0180	180	183,6	229	92	1,5x20	7x8	M6	25	5,53
HC 0200	200	203,6	247	102	1,5x20	7x8	M6	20	4,80
HC 0224	224	227,6	280	114	2x25	7x8	M6	15	6,15
HC 0250	250	253,6	306	127	2x25	7x8	M6	20	8,90
HC 0280	280	284,8	336	143	2x25	7x8	M6	20	9,84
HC 0300	300	304,8	357	153	2x25	7x8	M6	20	10,52
HC 0315	315	319,8	372	160	2x25	7x8	M6	20	11,02
HC 0355	355	359,8	412	180	2x25	7x8	M6	20	12,28
HC 0400	400	404,8	457	205	2x25	7x8	M6	20	13,76
HC 0450	450	454,8	507	230	2x25	7x8	M6	15	11,64
HC 0500	500	504,8	557	255	2x25	7x8	M6	10	9,04
HC 0560	560	564,8	627	285	2,5x25	11x13	M10	10	11,84
HC 0600	600	604,8	667	305	2,5x25	11x13	M10	10	12,60
HC 0630	630	636	697	320	2,5x25	11x13	M10	10	13,18
HC 0710	710	716	777	360	2,5x25	11x13	M10	10	14,92
HC 0800	800	806	867	405	2,5x25	11x13	M10	10	16,64
HC 0900	900	906	967	455	2,5x25	11x13	M10	8	15,08
HC 1000	1000	1007,2	1069	505	2,5x25	11x13	M10	8	17,22
HC 1120	1120	1127,2	1189	565	2,5x25	11x13	M10	4	9,52
HC 1250	1250	1257,2	1319	630	2,5x25	11x13	M10	4	11,26
HC 1400	1400	1407,2	1469	705	2,5x25	11x13	M10	4	12,41

Ventilation Pipe Clamp without Nut without Rubber

Скоба за вентилационна тръба - без гайка и без гума



Application

Used with Ventilation pipes.

Mounting Example

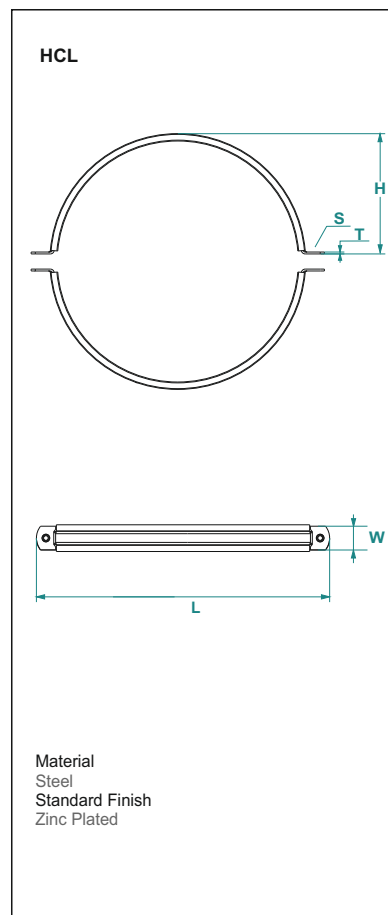

HCL

CODE	SIZE	PIPE DIAMETER (Ø) (mm)	LENGTH (L) (mm)	HEIGHT (H) (mm)	SHEET (TxW) (mm)	HOLE SIZE (mm)	ROD (metric)	QUANTITY (PER BOX) (pc)	WEIGHT (AVERAGE KG)
HCL 0071	71	73,4	117	37	1,5x20	7x8	M6	40	3,04
HCL 0080	80	82,4	126	42	1,5x20	7x8	M6	35	2,94
HCL 0090	90	92,6	136	47	1,5x20	7x8	M6	35	3,19
HCL 0100	100	103,6	147	52	1,5x20	7x8	M6	35	3,47
HCL 0112	112	115,6	159	58	1,5x20	7x8	M6	35	3,78
HCL 0125	125	128,6	172	65	1,5x20	7x8	M6	35	4,13
HCL 0140	140	143,6	186	72	1,5x20	7x8	M6	30	3,87
HCL 0150	150	153,6	197	77	1,5x20	7x8	M6	30	4,11
HCL 0160	160	163,6	209	82	1,5x20	7x8	M6	30	4,38
HCL 0180	180	183,6	229	92	1,5x20	7x8	M6	25	4,08
HCL 0200	200	203,6	247	102	1,5x20	7x8	M6	20	3,56
HCL 0224	224	227,6	280	114	2x25	7x8	M6	15	4,97
HCL 0250	250	253,6	306	127	2x25	7x8	M6	20	7,14
HCL 0280	280	284,8	336	143	2x25	7x8	M6	20	7,88
HCL 0300	300	304,8	357	153	2x25	7x8	M6	20	8,40
HCL 0315	315	319,8	372	160	2x25	7x8	M6	20	8,78
HCL 0355	355	359,8	412	180	2x25	7x8	M6	20	9,76
HCL 0400	400	404,8	457	205	2x25	7x8	M6	20	10,90
HCL 0450	450	454,8	507	230	2x25	7x8	M6	15	9,23
HCL 0500	500	504,8	557	255	2x25	7x8	M6	10	7,24
HCL 0560	560	564,8	627	285	2,5x25	11x13	M10	10	9,85
HCL 0600	600	604,8	667	305	2,5x25	11x13	M10	10	10,46
HCL 0630	630	636	697	320	2,5x25	11x13	M10	10	10,93
HCL 0710	710	716	777	360	2,5x25	11x13	M10	10	12,36
HCL 0800	800	806	867	405	2,5x25	11x13	M10	10	13,75
HCL 0900	900	906	967	455	2,5x25	11x13	M10	8	12,48
HCL 1000	1000	1007,2	1069	505	2,5x25	11x13	M10	8	14,30
HCL 1120	1120	1127,2	1189	565	2,5x25	11x13	M10	4	7,89
HCL 1250	1250	1257,2	1319	630	2,5x25	11x13	M10	4	9,44
HCL 1400	1400	1407,2	1469	705	2,5x25	11x13	M10	4	10,37

Sliding Hinge

Плъзгаща се панта



KM 30x40x250



KM 50x50x250

Application

Used for eliminating the lengthening and shortening problems which related to heat change about expansion feature of the pipes

Mounting Example



KM 30x40x250

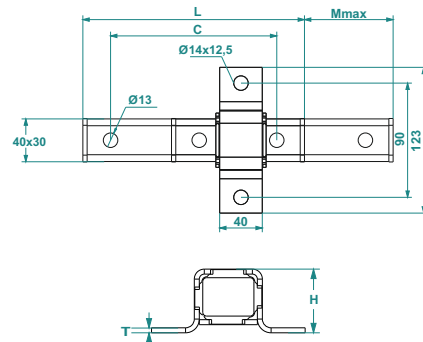

KM 50x50x250

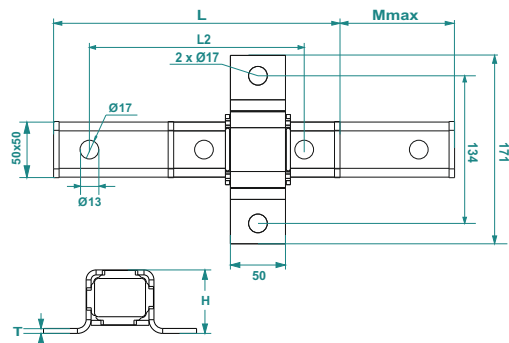

Material
Steel
Standard Finish
Zinc Plated

KM

CODE	SIZE	LENGTH (L) (mm)	HEIGHT (H) (mm)	HOLE SIZE (L2) (mm)	MESAFESI (Mmax) (mm)	HOLE DIAMETER (Ø) (mm)	QUANTITY (PER BOX) (pc)	WEIGHT (AVERAGE KG)
KM 3040200	30x40x2x200	208	51	145	85	13	10	6,76
KM 3040250	30x40x2x250	258	51	195	135	13	10	7,6
KM 5050250	50x50x3x250	260	76	195	127	13 / 17	10	17,8

Polyurethane Insulation Support

Полиуретанова опора за изолация



Application

Used for eliminating the heat losses inside of the pipes within hot-cold pipe installations

PIT

L:50 mm

CODE	SIZE	PIPE SIZE (ØD) (mm)	THICKNESS (mm)	LENGTH (L)	OUTER SIZE OF SUPPORT (ØD) (mm)	SUITABLE PIPE CLAMP SIZE
PIT 015	1/2"	21,3	20	50	61,3	2"
PIT 020	3/4"	26,9	20	50	66,9	67-75
PIT 025	1"	33,7	20	50	73,7	67-75
PIT 032	1 1/4"	42,4	20	50	82,4	83-91
PIT 040	1 1/2"	48,3	20	50	88,3	3"
PIT 050	2"	60,3	20	50	100,3	95-104
PIT 065	2 1/2"	76,1	30	50	136,1	5"
PIT 080	3"	88,9	30	50	148,9	5"
PIT 100	4"	114,3	30	50	174,3	6"
PIT 125	5"	139,7	30	50	199,7	196-209
PIT 150	6"	168,3	30	50	228,3	8"
PIT 200	8"	219,1	30	50	279,1	10"
PIT 250	10"	273	30	50	333,0	12"
PIT 300	12"	324	30	50	384,0	380-390
PIT 350	14"	355,6	30	50	415,6	16"
PIT 400	16"	406,4	30	50	466,4	18"

PIT

L:60 mm

CODE	SIZE	PIPE SIZE (ØD) (mm)	THICKNESS (mm)	LENGTH (L)	OUTER SIZE OF SUPPORT (ØD) (mm)	SUITABLE PIPE CLAMP SIZE
PIT 015 60	1/2"	21,3	20	60	61,3	2"
PIT 020 60	3/4"	26,9	20	60	66,9	67-75
PIT 025 60	1"	33,7	20	60	73,7	67-75
PIT 032 60	1 1/4"	42,4	20	60	82,4	83-91
PIT 040 60	1 1/2"	48,3	20	60	88,3	3"
PIT 050 60	2"	60,3	20	60	100,3	95-104
PIT 065 60	2 1/2"	76,1	30	60	136,1	5"
PIT 080 60	3"	88,9	30	60	148,9	5"
PIT 100 60	4"	114,3	30	60	174,3	6"
PIT 125 60	5"	139,7	30	60	199,7	196-209
PIT 150 60	6"	168,3	30	60	228,3	8"
PIT 200 60	8"	219,1	30	60	279,1	10"
PIT 250 60	10"	273	30	60	333,0	12"
PIT 300 60	12"	324	30	60	384,0	380-390
PIT 350 60	14"	355,6	30	60	415,6	16"
PIT 400 60	16"	406,4	30	60	466,4	18"

PIT

L:100 mm

CODE	SIZE	PIPE SIZE (ØD) (mm)	THICKNESS (mm)	LENGTH (L)	OUTER SIZE OF SUPPORT (ØD) (mm)	SUITABLE PIPE CLAMP SIZE
PIT 015 100	1/2"	21,3	20	100	61,3	2"
PIT 020 100	3/4"	26,9	20	100	66,9	67-75
PIT 025 100	1"	33,7	20	100	73,7	67-75
PIT 032 100	1 1/4"	42,4	20	100	82,4	83-91
PIT 040 100	1 1/2"	48,3	20	100	88,3	3"
PIT 050 100	2"	60,3	20	100	100,3	95-104
PIT 065 100	2 1/2"	76,1	30	100	136,1	5"
PIT 080 100	3"	88,9	30	100	148,9	5"
PIT 100 100	4"	114,3	30	100	174,3	6"
PIT 125 100	5"	139,7	30	100	199,7	196-209
PIT 150 100	6"	168,3	30	100	228,3	8"
PIT 200 100	8"	219,1	30	100	279,1	10"
PIT 250 100	10"	273	30	100	333,0	12"
PIT 300 100	12"	324	30	100	384,0	380-390
PIT 350 100	14"	355,6	30	100	415,6	16"
PIT 400 100	16"	406,4	30	100	466,4	18"

PIT

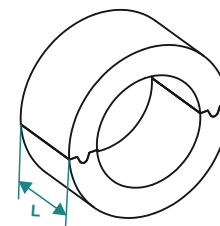
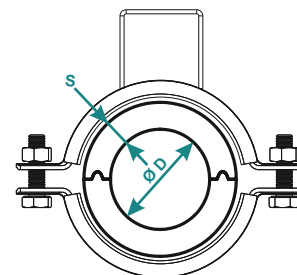

Mounting Example



Material
Polyurethane

Pipe Clamps



ЕНЕРДЖИ ГРУП ООД

U-Bolt Pipe Clamp

U-образна скоба за тръба

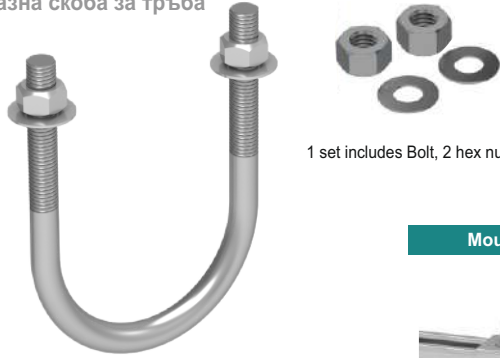

1 set includes Bolt, 2 hex nut, 2 plain washers

Mounting Example



Application

Used for fixing the pipe lines to walls or profiles in building sector.
U bolt size is determined according to supported pipe.

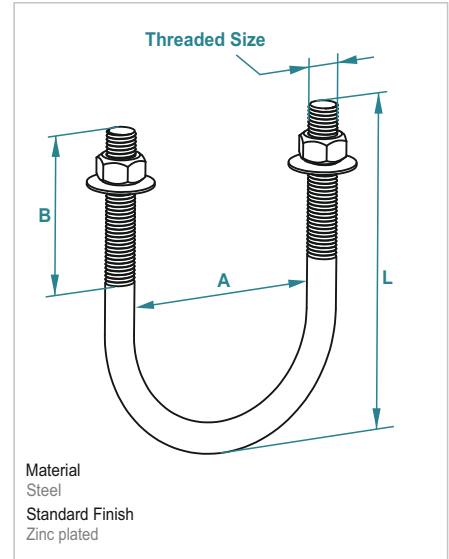

UB

CODE	PIPE SIZE		PRODUCT DESCRIPTION	THREAD SIZE	DIMENSIONS			LOAD	WEIGHT
	NOMINAL	Ø			A	L	B		
	NB	OUTER DIAMETER			mm	mm	mm		
UB 15 M6 EG	15	21,3	1/2" U bolt M6x50 with 2pc - M6 Hex nuts & Plain washers - EG	M6	24	50	30	0,64	0,020
UB 20 M6 EG	20	26,9	3/4" U bolt M6x60 with 2pc - M6 Hex nuts & Plain washers - EG	M6	30	60	30	0,64	0,024
UB 25 M8 EG	25	33,7	1" U bolt M8x70 with 2pc - M8 Hex nuts & Plain washers - EG	M8	36	70	30	0,64	0,053
UB 32 M8 EG	32	42,4	1 1/4" U bolt M8x80 with 2pc - M8 Hex nuts & Plain washers - EG	M8	46	80	40	0,64	0,061
UB 40 M8 EG	40	48,3	1 1/2" U bolt M8x90 with 2pc - M8 Hex nuts & Plain washers - EG	M8	52	90	50	0,64	0,068
UB 50 M10 EG	50	60,3	2" U bolt M10x100 with 2pc - M10 Hex nuts & Plain washers - EG	M10	64	100	50	1,62	0,121
UB 65 M10 EG	65	76,1	2 1/2" U bolt M10x120 with 2pc - M10 Hex nuts & Plain washers - EG	M10	78	120	50	1,62	0,145
UB 80 M12 EG	80	88,9	3" U bolt M12x140 with 2pc - M12 Hex nuts & Plain washers - EG	M12	94	140	60	3	0,245
UB 90 M12 EG	90	101,6	3 1/2" U bolt M12x150 with 2pc - M12 Hex nuts & Plain washers - EG	M12	106	150	65	3	0,264
UB 100 M12 EG	100	114,3	4" U bolt M12x160 with 2pc - M12 Hex nuts & Plain washers - EG	M12	118	160	65	3	0,283
UB 125 M12 EG	125	139,7	5" U bolt M12x200 with 2pc - M12 Hex nuts & Plain washers - EG	M12	146	200	65	3	0,352
UB 150 M16 EG	150	165,3	6" U bolt M16x220 with 2pc - M16 Hex nuts & Plain washers - EG	M16	172	220	90	3,65	0,739
UB 200 M16 EG	200	219,1	8" U bolt M16x270 with 2pc - M16 Hex nuts & Plain washers - EG	M16	224	270	90	3,65	0,914
UB 250 M16 EG	250	273	10" U bolt M16x334 with 2pc - M16 Hex nuts & Plain washers - EG	M16	278	334	100	3,65	1,128
UB 300 M16 EG	300	324	12" U bolt M16x380 with 2pc - M16 Hex nuts & Plain washers - EG	M16	328	380	100	3,65	1,290
UB 350 M18 EG	350	355,6	14" U bolt M18x413 with 2pc - M18 Hex nuts & Plain washers - EG	M18	360	413	100	4	1,811
UB 400 M20 EG	400	406,4	16" U bolt M20x470 with 2pc - M20 Hex nuts & Plain washers - EG	M20	412	470	120	4,8	2,584
UB 450 M20 EG	450	457	18" U bolt M20x520 with 2pc - M20 Hex nuts & Plain washers - EG	M20	464	520	120	4,8	2,866
UB 500 M24 EG	500	508	20" U bolt M24x582 with 2pc - M24 Hex nuts & Plain washers - EG	M24	514	582	120		4,711
UB 600 M24 EG	600	610	24" U bolt M24x700 with 2pc - M24 Hex nuts & Plain washers - EG	M24	616	700	120		5,653

Collector Clamp 1"

Скоба за колектор - 1"



Mounting Example



Application

Used for fixing the steel collectors by mounting into collector cabinets.

KOL

CODE	PRODUCT DESCRIPTION	WEIGHT	QUANTITY PER BOX	BOX WIGHT
		Kg	Pcs	Kg
KOL	1" Collector Clamp	0,151	40	6,04

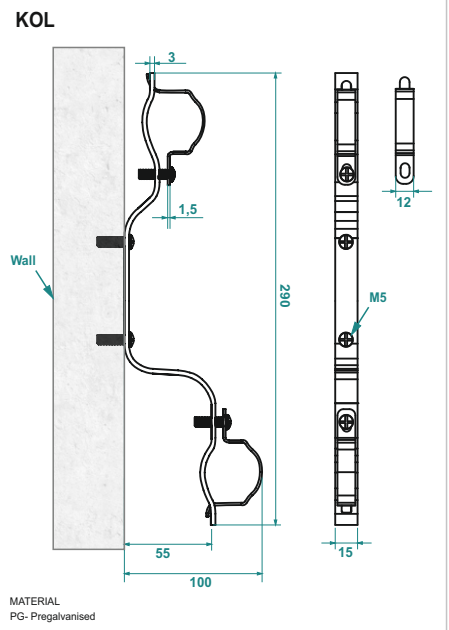

Hanging C Rail (27x18)

Висяща "С" релса



Pre-Galvanized EN 10346

CL...A						
CODE	Size mm WxH	Thickness T mm	Hole Size mm	Length L mm	KG 1mt	pcs
CL 2718A 10 PG	27x18	1,0	8,5x20 & Ø 11	2000	0,51	50
CL 2718A 12 PG	27x18	1,2	8,5x20 & Ø 11	2000	0,60	50

Hanging C Rail (28x30)

Висяща "С" релса



Pre-Galvanized EN 10346

CL...A						
CODE	Size mm WxH	Thickness T mm	Hole Size mm	Length L mm	KG 1mt	pcs
CL 2830A 15 PG	28x30	1,5	8,5x20 & Ø 11	2000	1,05	50
CL 2830A 18 PG	28x30	1,8	8,5x20 & Ø 11	2000	1,29	50

Hanging C Rail (38x40)

Висяща "С" релса



Pre-Galvanized EN 10346

CL...C						
CODE	Size mm WxH	Thickness T mm	Hole Size mm	Length L mm	KG 1mt	pcs
CL 3840C 15 PG	38x40	1,5	13x25	2000	1,47	50
CL 3840C 18 PG	38x40	1,8	13x25	2000	1,74	50
CL 3840C 20 PG	38x40	2,0	13x25	2000	1,92	50

Hanging C Rail (60x40)

Висяща "С" релса



Pre-Galvanized EN 10346

CL...C						
CODE	Size mm WxH	Thickness T mm	Hole Size mm	Length L mm	KG 1mt	pcs
CL 4060C 20 PG	40x60	2,0	13x25	3000	2,64	50
CL 4060C 25 PG	40x60	2,5	13x25	3000	3,24	50
CL 4060C 30 PG	40x60	3,0	13x25	3000	3,82	50

CL 2718A...
 8,5x20
 Ø11
 27
 18
 7

CL 2830A...
 8,5x20
 Ø11
 28
 30
 8

CL 3840C...
 13x25
 38
 40
 10

CL 4060C...
 13x25
 40
 60
 12

MATERIAL
 Steel, strip-galv. acc. to the sendzimir method to TS-EN 10346:2011 (PG)
 Available finishes:
 HDG-steel, hot-dip galv. to TS-EN ISO 1461:2011 (HDG)
 Thickn. (ga) [mm]: 1.5 2.0 2.5 3.0

C Channel 21x41

"C" профил



C 2141A
Perforated

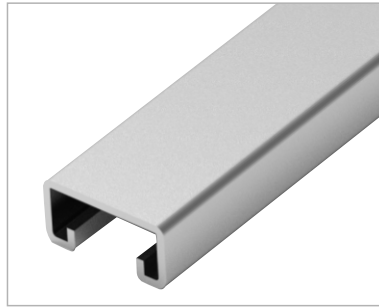

C 2141
Non-Perforated

Pre-Galvanized

C 2141A		1.5 mm		2.0 mm		2.5 mm			
CODE	Thickness T mm	Length L mm	kg 1 m	pcs	CODE	Thickness T mm	Length L mm	kg 1 m	pcs
C 2141A 15 PG	1,5	3000	1,05	50	C 2141A 20 PG	2,0	3000	1,42	50
					C 2141A.40 20 PG	2,0	4000	1,42	50
					C 2141A.60 20 PG	2,0	6000	1,42	50
					C 2141A 25 PG	2,5	3000	1,77	50
					C 2141A.60 25 PG	2,5	6000	1,77	50

Pre-Galvanized

C 2141		1.5 mm		2.0 mm		2.5 mm			
CODE	Thickness T mm	Length L mm	kg 1 m	pcs	CODE	Thickness T mm	Length L mm	kg 1 m	pcs
C 2141 15 PG	1,5	3000	1,10	50	C 2141 20 PG	2,0	3000	1,46	50
					C 2141.40 20 PG	2,0	4000	1,46	50
					C 2141.60 20 PG	2,0	6000	1,46	50
					C 2141 25 PG	2,5	3000	1,80	50
					C 2141.60 25 PG	2,5	6000	1,80	50

C Double Channel 42x41 (Welded)

"C" профил 42x41 / заварен



C 4241A
Perforated

Pre-Galvanized

C 4241A		2.0 mm		2.5 mm					
CODE	Thickness T mm	Length L mm	kg 1 m	pcs	CODE	Thickness T mm	Length L mm	kg 1 m	pcs
C 4241A 20 PG	2,0	3000	2,86	50	C 4241 25 PG	2,5	3000	3,58	50
C 4241A.60 20 PG	2,0	6000	2,86	50	C 4241A.60 25 PG	2,5	6000	3,58	50



C 4241
Non-Perforated

Pre-Galvanized

C 4241		2.0 mm		2.5 mm					
CODE	Thickness T mm	Length L mm	kg 1 m	pcs	CODE	Thickness T mm	Length L mm	kg 1 m	pcs
C 4241 20 PG	2,0	3000	2,92	50	C 2141 25 PG	2,5	3000	3,60	50
C 4241.60 20 PG	2,0	6000	2,92	50	C 2141.60 25 PG	2,5	6000	3,60	50

C 2141A

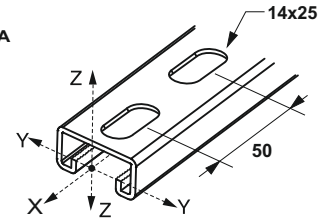

C 2141

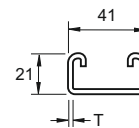
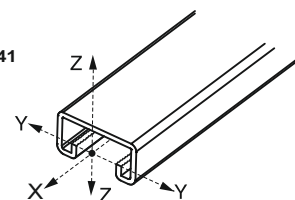

C 2141A	Unit	Z - Z AXIS			Y - Y AXIS		
		1,5	2,0	2,5	1,5	2,0	2,5
Moment of Inertia	cm ⁴	3,34	4,25	5,07	0,7	0,88	1,03
Section Modulus	cm ³	1,68	1,88	2,59	0,6	0,75	0,89
Allowable Bending Stress	kN/cm ²	21,82	21,82	21,82	21,82	21,82	21,82

C 4241A

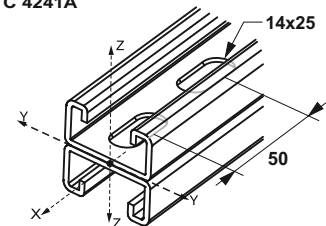

C 4241

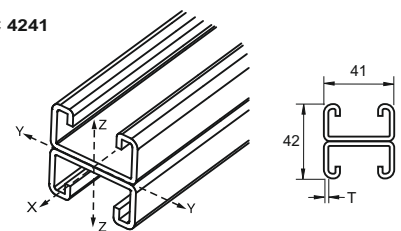

C 4241A	Unit	Z - Z AXIS		Y - Y AXIS	
		2,0	2,5	2,0	2,5
Moment of Inertia	cm ⁴	8,51	10,14	4,60	5,55
Section Modulus	cm ³	4,26	5,18	2,19	2,65
Allowable Bending Stress	kN/cm ²	21,82	21,82	21,82	21,82

APPLICATIONS

Cable routing

MATERIAL

Steel, strip-galv. acc. to the sendzimir method to TS-EN 10346:2011 (PG)

Available finishes:

HDG-steel, hot-dip galv. to TS-EN ISO 1461:2011 (HDG)

Thickn. (ga) [mm]: **1.5 2.0 2.5**

C Channel 41x41

"C" профил 41x41



C 4141A
Perforated

Pre-Galvanized



C 4141A		1.5 mm		2.0 mm		2.5 mm			
CODE	Thickness T mm	Length L mm	kg 1 m	pcs	CODE	Thickness T mm	Length L mm	kg 1 m	pcs
C 4141A 15 PG	1.5	3000	1.52	50	C 4141A 20 PG	2.0	3000	2.06	50
C 4141A 40 20 PG	2.0	4000	2.06	50	C 4141A 60 20 PG	2.0	6000	2.06	50
C 4141A 25 PG	2.5	3000	2.57	50	C 4141A 60 25 PG	2.5	6000	2.57	50

C 4141
Non-Perforated

Pre-Galvanized



C 4141		1.5 mm		2.0 mm		2.5 mm			
CODE	Thickness T mm	Length L mm	kg 1 m	pcs	CODE	Thickness T mm	Length L mm	kg 1 m	pcs
C 4141 15 PG	1.5	3000	1.58	50	C 4141 20 PG	2.0	3000	2.12	50
C 4141 40 20 PG	2.0	4000	2.12	50	C 4141 60 20 PG	2.0	6000	2.12	50
C 4141 25 PG	2.5	3000	2.68	50	C 4141 60 25 PG	2.5	6000	2.68	50

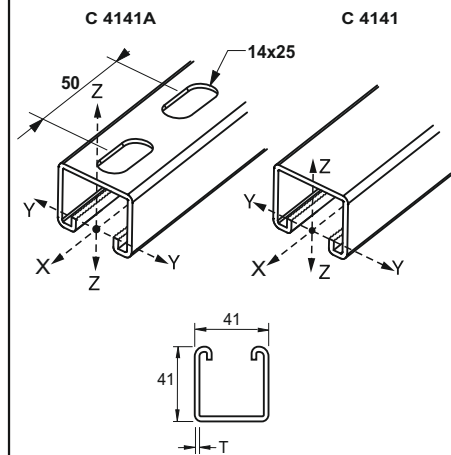

C 4141A	Unit	Z - Z AXIS			Y - Y AXIS		
		1,5	2,0	2,5	1,5	2,0	2,5
Moment of Inertia	cm ⁴	5,68	6,99	8,67	3,87	4,59	5,87
Section Modulus	cm ³	3,58	4,26	5,18	1,76	2,18	2,72
Allowable Bending Stress	kN/cm ²	21,82	21,82	21,82	21,82	21,82	21,82

C Double Channel 83x41 (Welded)

"C" профил 83x41 / заварен

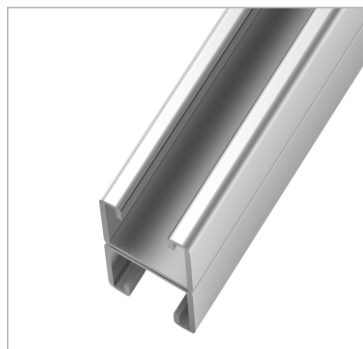

C 8341A
Perforated

Pre-Galvanized



C 8341A		2.0 mm		2.5 mm					
CODE	Thickness T mm	Length L mm	kg 1 m	pcs	CODE	Thickness T mm	Length L mm	kg 1 m	pcs
C 8341A 20 PG	2.0	3000	4.12	50	C 8341A 25 PG	2.5	3000	5.15	50
C 8341A 60 20 PG	2.0	6000	4.12	50	C 8341A 60 25 PG	2.5	6000	5.15	50

C 8341
Non-Perforated

Pre-Galvanized



C 8341		2.0 mm		2.5 mm					
CODE	Thickness T mm	Length L mm	kg 1 m	pcs	CODE	Thickness T mm	Length L mm	kg 1 m	pcs
C 8341 20 PG	2.0	3000	2.92	50	C 8341 25 PG	2.5	3000	3.60	50
C 8341 60 20 PG	2.0	6000	2.92	50	C 8341 60 25 PG	2.5	6000	3.60	50

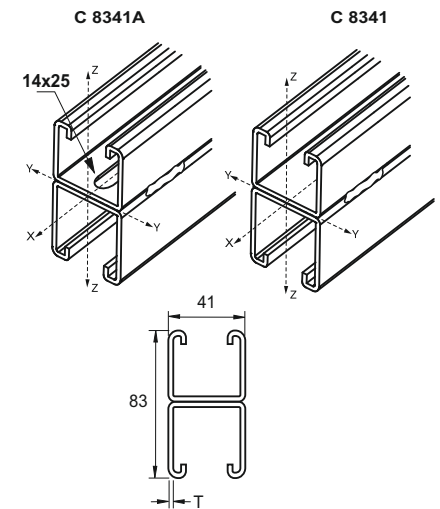

C 8341A	Unit	Z - Z AXIS		Y - Y AXIS	
		2,0	2,5	2,0	2,5
Moment of Inertia	cm ⁴	14,04	17,56	26,81	34,08
Section Modulus	cm ³	6,82	8,94	6,62	8,31
Allowable Bending Stress	kN/cm ²	21,82	21,82	21,82	21,82

APPLICATIONS

Cable routing

MATERIAL

Steel, strip-galv. acc. to the sendzimir method to TS-EN 10346:2011 (PG)

Available finishes:

HDG-steel, hot-dip galv. to TS-EN ISO 1461:2011 (HDG)

Thickn. (ga) [mm]: **1.5 2.0 2.5**

C Channel 62X41

"C" профил 62x41



C 6241A
Perforated



Pre-Galvanized

C 6241A					2.0 mm
CODE	Thickness T mm	Length L mm	KG 1 m	pcs	
C 6241A.20 PG	2.0	3000	2.70	50	
C 6241A.60 20 PG	2.0	6000	2.70	50	
					2.5 mm
CODE	Thickness T mm	Length L mm	KG 1 m	pcs	
C 6241A.25 PG	2.5	3000	3.36	50	
C 6241A.60 25 PG	2.5	6000	3.36	50	

C 6241
Non-Perforated



Pre-Galvanized

C 6241					2.0 mm
CODE	Thickness T mm	Length L mm	KG 1 m	pcs	
C 6241 20 PG	2.0	3000	2.80	50	
C 6241.60 20 PG	2.0	6000	2.80	50	
					2.5 mm
CODE	Thickness T mm	Length L mm	KG 1 m	pcs	
C 6241 25 PG	2.5	3000	3.45	50	
C 6241.60 25 PG	2.5	6000	3.45	50	

C 6241A

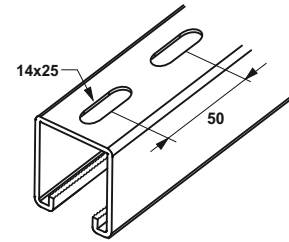

C 6241

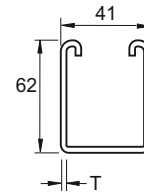
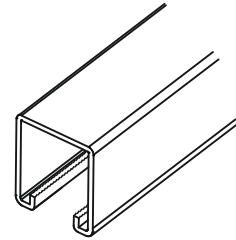

C Double Channel 124x41 (Welded)

"C" профил 124x41 / заварен



C 12441A
Perforated



Pre-Galvanized

C 12441A					2.0 mm
CODE	Thickness T mm	Length L mm	KG 1 m	pcs	
C 12441A.20 PG	2.0	3000	5.40	50	
C 12441A.60 20 PG	2.0	6000	5.40	50	
					2.5 mm
CODE	Thickness T mm	Length L mm	KG 1 m	pcs	
C 12441A.25 PG	2.5	3000	6.72	50	
C 12441A.60 25 PG	2.5	6000	6.72	50	

C 12441
Non-Perforated



Pre-Galvanized

C 12441					2.0 mm
CODE	Thickness T mm	Length L mm	KG 1 m	pcs	
C 12441A.20 PG	2.0	3000	5.60	50	
C 12441A.60 25 PG	2.0	6000	5.60	50	
					2.5 mm
CODE	Thickness T mm	Length L mm	KG 1 m	pcs	
C 12441A.25 PG	2.5	3000	6.90	50	
C 12441A.60 25 PG	2.5	6000	6.90	50	

C 12441A

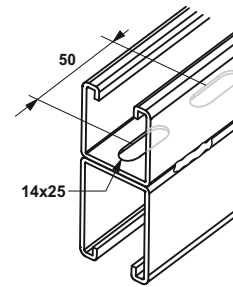

C 12441

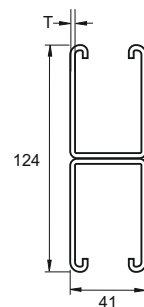
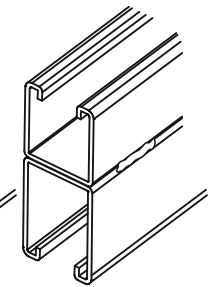

APPLICATIONS

Cable routing

MATERIAL

Steel, strip-galv. acc. to the sendzimir method to TS-EN 10346:2011 (PG)

Available finishes:

HDG-steel, hot-dip galv. to TS-EN ISO 1461:2011 (HDG)

Thickn. (ga) [mm]: 1.5 2.0 2.5

U Profile "U" профил

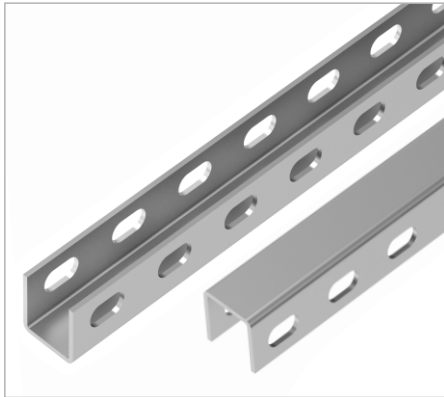

Mounting Example

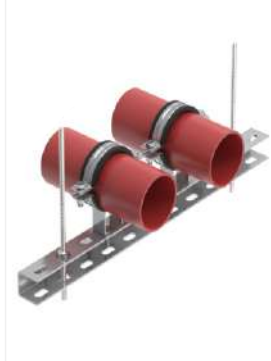

Electrozinc Plated

UH		L:2000								
CODE	Size W x H mm	Thickness T mm	Hole Size A x B mm	C mm	D mm	Length L mm	kg 1 m	pcs		
UH 3030B 20 EG	30x30	2.0	11x20	40	12	2000	1.14	50		
UH 3030B 25 EG	30x30	2.5	11x20	40	12	2000	1.37	50		
UH 3030B 30 EG	30x30	3.0	11x20	40	12	2000	1.64	50		
UH 4040C 25 EG	40x40	2.5	12x25	50	16	2000	1.77	50		
UH 4040C 30 EG	40x40	3.0	12x25	50	16	2000	2.15	50		
UH 4040C 40 EG	40x40	4.0	12x25	50	16	2000	2.90	50		
UH 5050C 30 EG	50x50	3.0	12x25	50	20	2000	2.81	50		
UH 5050C 40 EG	50x50	4.0	12x25	50	20	2000	3.74	50		

L Profile "L" профил

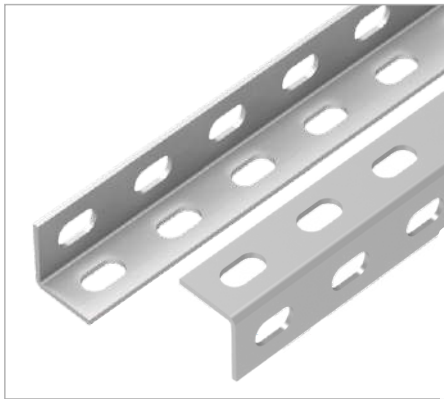

Mounting Example



Electrozinc Plated

L		L:2000								
CODE	Size W x H mm	Thickness T mm	Hole Size mm	C mm	D mm	Length L mm	kg 1 m	pcs		
L 30B 20 EG	30x30	2.0	11x20	40	12	2000	0.73	50		
L 30B 25 EG	30x30	2.5	11x20	40	12	2000	0.90	50		
L 30B 30 EG	30x30	3.0	11x20	40	12	2000	1.08	50		
L 40C 25 EG	40x40	2.5	12x25	50	16	2000	1.19	50		
L 40C 30 EG	40x40	3.0	12x25	50	16	2000	1.45	50		
L 40C 40 EG	40x40	4.0	12x25	50	16	2000	1.90	50		
L 50C 30 EG	50x50	3.0	12x25	50	20	2000	1.88	50		
L 50C 40 EG	50x50	4.0	12x25	50	20	2000	2.46	50		

UH... B

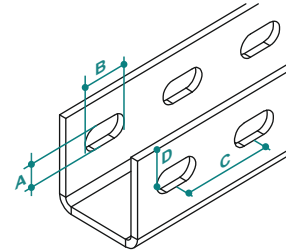
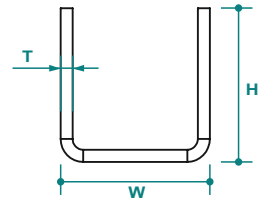

L

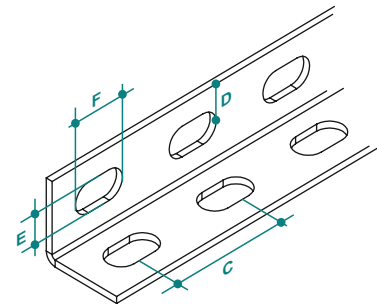
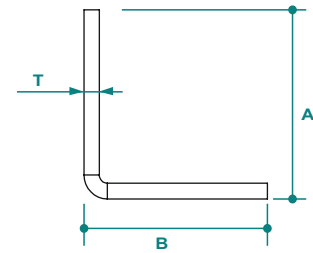

MATERIAL

Electrozinc plated - Elektro Galvaniz Kaplama

Available finishes:

HDG-steel, hot-dip galv. to TS-EN ISO 1461:2011 (HDG)

Thickn. (ga) [mm]: 1.5 2.0 2.5 3.0

CL Channel 27x18 Bracket

CL профилна конзола 27x18



Electro-Galvanized

CL27		1.2 mm		
CODE	Thickness T mm	Length L mm	kg 1 m	pcs
CL27 200 12 EG	1.2	200	0.29	1
CL27 300 12 EG	1.2	300	0.36	1
CL27 400 12 EG	1.2	400	0.43	1
CL27 500 12 EG	1.2	500	0.50	1

CL Channel 28x30 Bracket

CL профилна конзола 28x30



Electro-Galvanized

CL28		1.5 mm		
CODE	Thickness T mm	Length L mm	kg 1 m	pcs
CL28 200 15 EG	1.5	200	0.38	1
CL28 250 15 EG	1.5	250	0.43	1
CL28 300 15 EG	1.5	300	0.49	1
CL28 350 15 EG	1.5	350	0.55	1
CL28 400 15 EG	1.5	400	0.60	1
CL28 450 15 EG	1.5	450	0.66	1
CL28 500 15 EG	1.5	500	0.72	1
CL28 550 15 EG	1.5	550	0.77	1
CL28 600 15 EG	1.5	600	0.83	1

CL Channel 38x40 Bracket

CL профилна конзола 38x40



Electro-Galvanized

CL38		2.0 mm		
CODE	Thickness T mm	Length L mm	kg 1 m	pcs
CL38 200 20 EG	2.0	200	0.68	1
CL38 250 20 EG	2.0	250	0.79	1
CL38 300 20 EG	2.0	300	0.89	1
CL38 350 20 EG	2.0	350	0.99	1
CL38 400 20 EG	2.0	400	1.09	1
CL38 450 20 EG	2.0	450	1.19	1
CL38 500 20 EG	2.0	500	1.30	1
CL38 550 20 EG	2.0	550	1.40	1
CL38 600 20 EG	2.0	600	1.50	1
CL38 700 20 EG	2.0	700	1.70	1
CL38 800 20 EG	2.0	800	1.91	1
CL38 1000 20 EG	2.0	1000	2.32	1

CL27

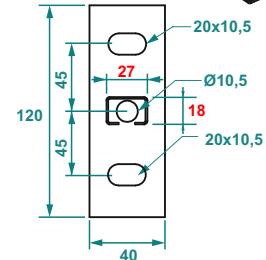
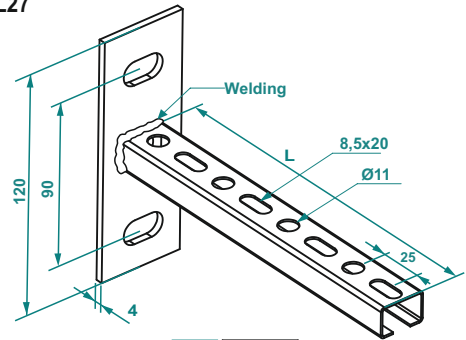

CL28

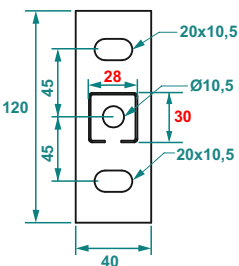
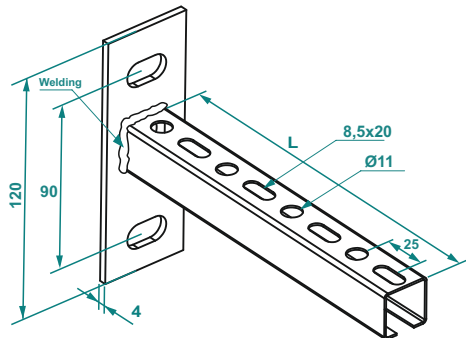

CL38

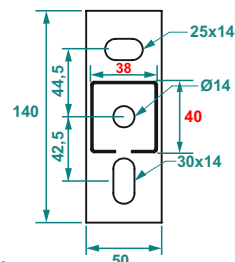
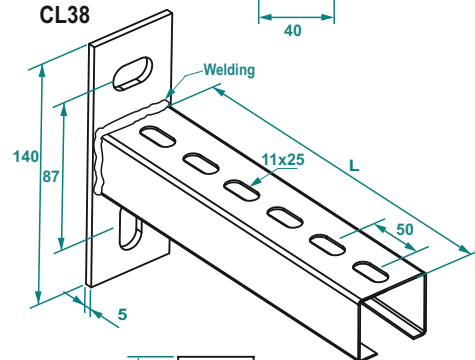

MATERIAL

EG: Electro-galvanised (8-12 micron) EN ISO 2081

Thickn. (ga) [mm]: 1.2 1.5 2.0

C Channel 21x41 Bracket

С профилна конзола 21X41

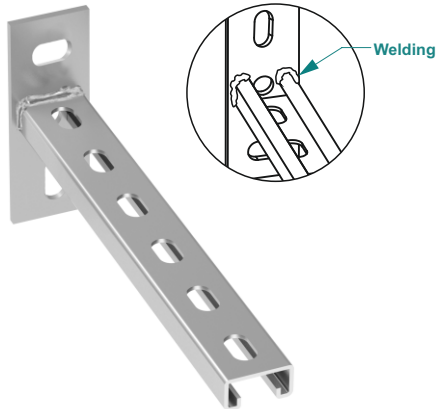

Length L mm	Base Plate Thickness S mm
100	5 mm
150	
200	
250	
300	
350	
400	
450	
500	
600	

Hot Dip Galvanised

C21	2.0mm			
	CODE	Thickness T mm	Length L mm	Weight kg 1 pc
C21 100 20 EG	2,0	100	0,43	1
C21 150 20 EG	2,0	150	0,51	1
C21 200 20 EG	2,0	200	0,59	1
C21 250 20 EG	2,0	250	0,67	1
C21 300 20 EG	2,0	300	0,75	1
C21 350 20 EG	2,0	350	0,83	1
C21 400 20 EG	2,0	400	0,91	1
C21 450 20 EG	2,0	450	0,99	1
C21 600 20 EG	2,0	600	1,23	1

Hot Dip Galvanised

C21	2.5mm			
	CODE	Thickness T mm	Length L mm	Weight kg 1 pc
C21 100 25 EG	2,5	100	0,47	1
C21 150 25 EG	2,5	150	0,56	1
C21 200 25 EG	2,5	200	0,66	1
C21 250 25 EG	2,5	250	0,75	1
C21 300 25 EG	2,5	300	0,85	1
C21 350 25 EG	2,5	350	0,94	1
C21 400 25 EG	2,5	400	1,04	1
C21 450 25 EG	2,5	450	1,13	1
C21 600 25 EG	2,5	600	1,46	1

C Channel 41x41 Bracket

С профилна конзола 41X41

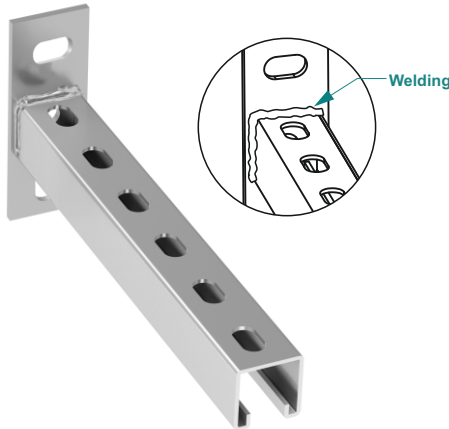

Length L mm	Base Plate Thickness S mm
100	5 mm
150	
200	
250	
300	
350	
400	
450	
500	
550	
600	6 mm
650	
700	
750	
800	
900	
950	
1000	

Hot Dip Galvanised

C41	2.0mm			
	CODE	Thickness T mm	Length L mm	Weight kg 1 pc
C41 100 20 EG	2,0	100	0,50	1
C41 150 20 EG	2,0	150	0,61	1
C41 200 20 EG	2,0	200	0,72	1
C41 250 20 EG	2,0	250	0,83	1
C41 300 20 EG	2,0	300	0,94	1
C41 350 20 EG	2,0	350	1,05	1
C41 400 20 EG	2,0	400	1,16	1
C41 450 20 EG	2,0	450	1,27	1
C41 500 20 EG	2,0	500	1,38	1
C41 550 20 EG	2,0	550	1,49	1
C41 600 20 EG	2,0	600	1,60	1
C41 650 20 EG	2,0	650	1,71	1
C41 700 20 EG	2,0	700	1,82	1
C41 750 20 EG	2,0	750	1,93	1
C41 800 20 EG	2,0	800	2,04	1
C41 900 20 EG	2,0	900	2,26	1
C41 950 20 EG	2,0	950	2,37	1
C41 1000 20 EG	2,0	1000	2,48	1

Hot Dip Galvanised

C41	2.5mm			
	CODE	Thickness T mm	Length L mm	Weight kg 1 pc
C41 100 25 EG	2,5	100	0,55	1
C41 150 25 EG	2,5	150	0,69	1
C41 200 25 EG	2,5	200	0,83	1
C41 250 25 EG	2,5	250	0,96	1
C41 300 25 EG	2,5	300	1,10	1
C41 350 25 EG	2,5	350	1,24	1
C41 400 25 EG	2,5	400	1,38	1
C41 450 25 EG	2,5	450	1,51	1
C41 500 25 EG	2,5	500	1,65	1
C41 550 25 EG	2,5	550	1,79	1
C41 600 25 EG	2,5	600	1,93	1
C41 650 25 EG	2,5	650	2,06	1
C41 700 25 EG	2,5	700	2,20	1
C41 750 25 EG	2,5	750	2,34	1
C41 800 25 EG	2,5	800	2,48	1
C41 900 25 EG	2,5	900	2,75	1
C41 950 25 EG	2,5	950	2,89	1
C41 1000 25 EG	2,5	1000	3,03	1

C21

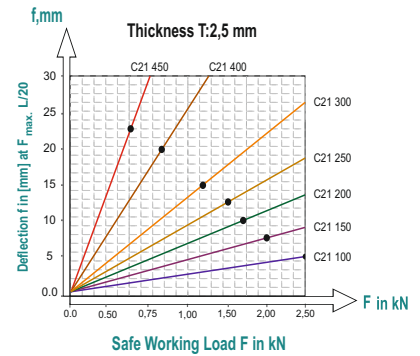
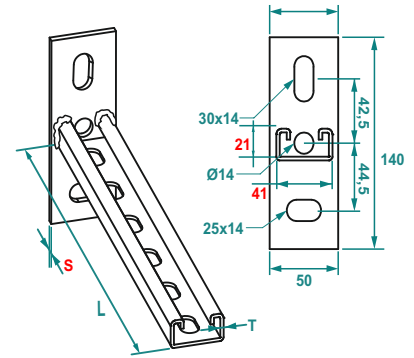

C41

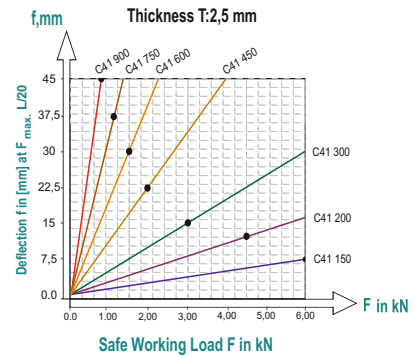
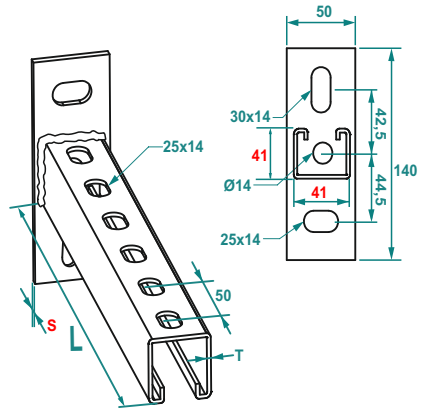

MATERIAL

EG: Electro-galvanised (8-12 Micron) EN ISO 2081

Available finishes:

Steel, strip-galv. acc. to TS-EN ISO 1461:2011 (HDG)

Thickn. (ga) [mm]: 2.0 2.5

C Channel 42x41 Bracket

C профилна конзола 42X41

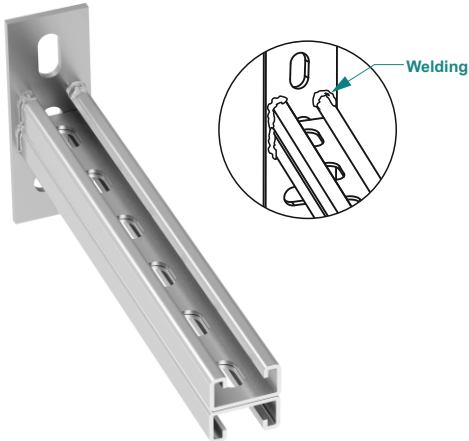

Length L mm	Base Plate Thickness S mm
200	5 mm
300	
350	
400	
450	
500	
550	
600	
650	
700	
750	
800	
	6 mm

Electro-Galvanized

C42		2.0mm			
CODE	Thickness T mm	Length L mm	kg 1 pc	pcs	
C42 200 20 EG	2.0	200	0.89	1	
C42 300 20 EG	2.0	300	1.20	1	
C42 350 20 EG	2.0	350	1.36	1	
C42 400 20 EG	2.0	400	1.51	1	
C42 450 20 EG	2.0	450	1.67	1	
C42 500 20 EG	2.0	500	1.82	1	
C42 550 20 EG	2.0	550	1.98	1	
C42 600 20 EG	2.0	600	2.13	1	
C42 650 20 EG	2.0	650	2.34	1	
C42 700 20 EG	2.0	700	2.50	1	
C42 750 20 EG	2.0	750	2.65	1	
C42 800 20 EG	2.0	800	2.81	1	

Electro-Galvanized

C42		2.5mm			
CODE	Thickness T mm	Length L mm	kg 1 pc	pcs	
C42 200 25 EG	2.5	200	1.03	1	
C42 300 25 EG	2.5	300	1.41	1	
C42 350 25 EG	2.5	350	1.60	1	
C42 400 25 EG	2.5	400	1.71	1	
C42 450 25 EG	2.5	450	1.98	1	
C42 500 25 EG	2.5	500	2.17	1	
C42 550 25 EG	2.5	550	2.36	1	
C42 600 25 EG	2.5	600	2.55	1	
C42 650 25 EG	2.5	650	2.80	1	
C42 700 25 EG	2.5	700	2.99	1	
C42 750 25 EG	2.5	750	3.18	1	
C42 800 25 EG	2.5	800	3.37	1	

C Channel 83x41 Bracket

C профилна конзола 83X41

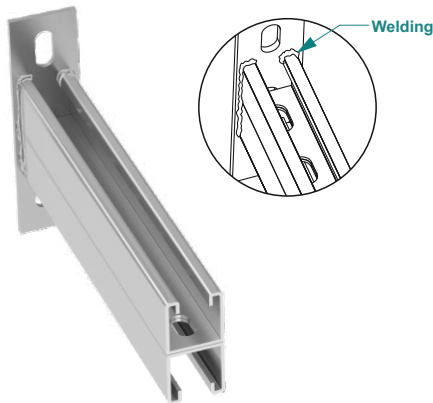

Length L mm	Base Plate Thickness S mm
200	6 mm
250	
300	
350	
400	
450	
500	
550	
600	
650	
700	
750	
800	
850	
900	
950	
1000	
	8 mm

Hot Dip Galvanized

C83		2.0mm			
CODE	Thickness T mm	Length L mm	kg 1 pc	pcs	
C83 200 20 EG	2.0	200	1.30	1	
C83 300 20 EG	2.0	300	1.74	1	
C83 350 20 EG	2.0	350	1.96	1	
C83 400 20 EG	2.0	400	2.18	1	
C83 450 20 EG	2.0	450	2.40	1	
C83 500 20 EG	2.0	500	2.62	1	
C83 550 20 EG	2.0	550	2.84	1	
C83 600 20 EG	2.0	600	3.06	1	
C83 650 20 EG	2.0	650	3.43	1	
C83 700 20 EG	2.0	700	3.65	1	
C83 750 20 EG	2.0	750	3.87	1	
C83 800 20 EG	2.0	800	4.09	1	
C83 850 20 EG	2.0	850	4.31	1	
C83 900 20 EG	2.0	900	4.53	1	
C83 950 20 EG	2.0	950	4.75	1	
C83 1000 20 EG	2.0	1000	4.97	1	
C83 1050 20 EG	2.0	1050	5.19	1	

Hot Dip Galvanized

C83		2.5mm			
CODE	Thickness T mm	Length L mm	kg 1 pc	pcs	
C83 200 25 EG	2.5	200	1.52	1	
C83 300 25 EG	2.5	300	2.07	1	
C83 350 25 EG	2.5	350	2.35	1	
C83 400 25 EG	2.5	400	2.62	1	
C83 450 25 EG	2.5	450	2.90	1	
C83 500 25 EG	2.5	500	3.17	1	
C83 550 25 EG	2.5	550	3.45	1	
C83 600 25 EG	2.5	600	3.72	1	
C83 650 25 EG	2.5	650	4.00	1	
C83 700 25 EG	2.5	700	4.42	1	
C83 750 25 EG	2.5	750	4.69	1	
C83 800 25 EG	2.5	800	4.97	1	
C83 850 25 EG	2.5	850	5.24	1	
C83 900 25 EG	2.5	900	5.52	1	
C83 950 25 EG	2.5	950	5.79	1	
C83 1000 25 EG	2.5	1000	6.07	1	
C83 1050 25 EG	2.5	1050	6.34	1	

C42

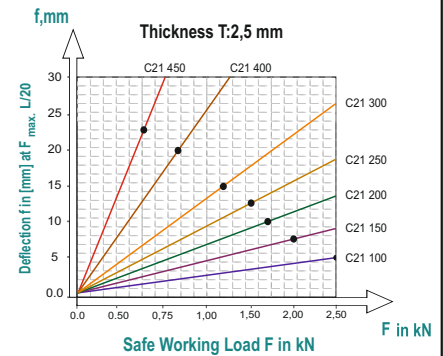
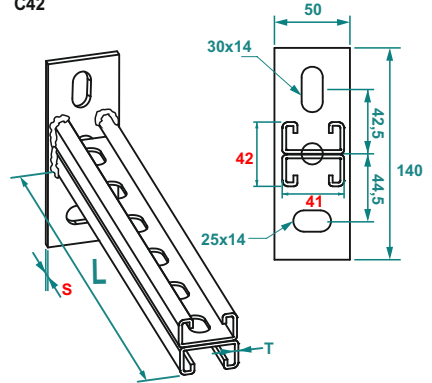

C83

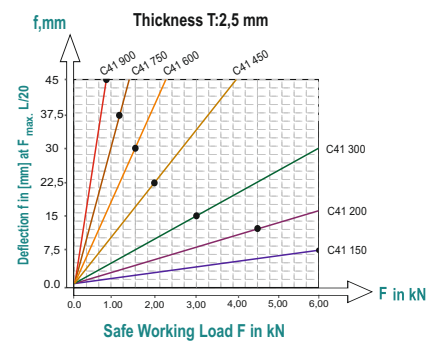
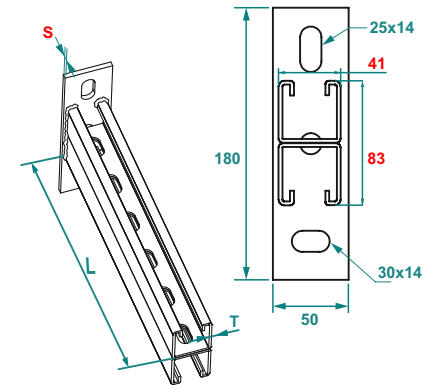

MATERIAL

EG: Electro-galvanized (8-12 Micron) EN ISO 2081

Available finishes:

Steel, strip-galv. acc. to TS-EN ISO 1461:2011 (HDG)

Thickn. (ga) [mm]: **2.0** **2.5**

27/28 C Rail Head Plate

"C" плоча на главата на релсата (27/28)

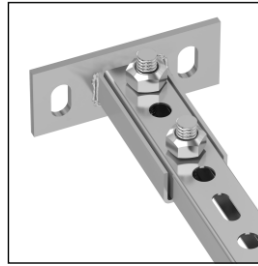
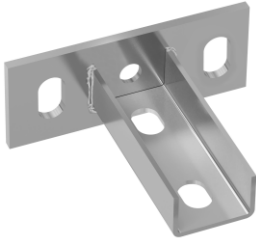

*Used with CL channels 27x18, 28x30

Electro-Galvanized

UT4 01		EG						
CODE	CHANNEL SUPPORT		BASE PLATE	LENGTH	LOAD Fz	kg 1 pc	pcs	
	Description	mm	mm	mm	kN			
UT4 01 EG	Crosswise	27/28	120x40x4	70	0,80	0,230	50	

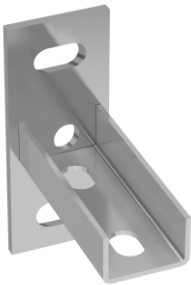

*Used with CL channels 27x18, 28x30

Electro-Galvanized

UT4 02		EG						
CODE	CHANNEL SUPPORT		BASE PLATE	LENGTH	LOAD Fz	kg 1 pc	pcs	
	Description	mm	mm	mm	kN			
UT4 02 EG	Lengthwise	27/28	120x40x4	70	0,80	0,230	50	

27/28 C Rail Head Plate

"C" плоча на главата на релсата (27/28)



*Used with CL channels 27x18, 28x30 * Pre-assembled with double rail nut

Electro-Galvanized

UT4 11		EG						
CODE	CHANNEL SUPPORT		BASE PLATE	LENGTH	DOUBLE RAIL NUT		kg 1 pc	pcs
	Description	mm	mm	mm	Size	Bolt		
UT4 11 EG	Crosswise	27/28	120x40x4	70	23x60x4	M8x15	0,330	50



*Used with CL channels 27x18, 28x30 * Pre-assembled with double rail nut

Electro-Galvanized

UT4 12		EG						
CODE	CHANNEL SUPPORT		BASE PLATE	LENGTH	DOUBLE RAIL NUT		kg 1 pc	pcs
	Description	mm	mm	mm	Size	Bolt		
UT4 12 EG	Lengthwise	27/28	120x40x4	70	23x60x4	M8x15	0,330	50

UT4 01 EG
Crosswise Model

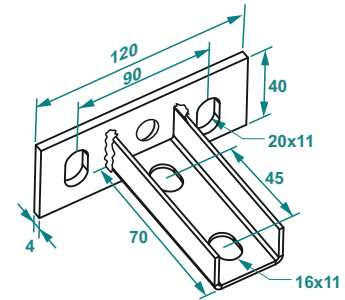

UT4 02 EG
Lengthwise Model

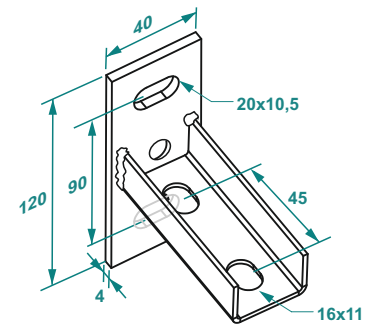

UT4 11 EG
Crosswise Model

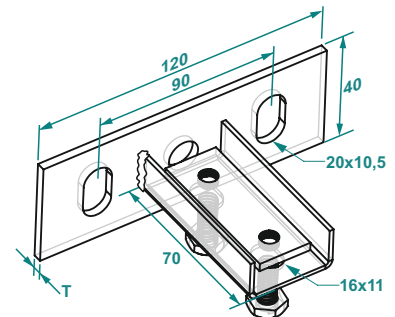

UT4 12 EG
Lengthwise Model

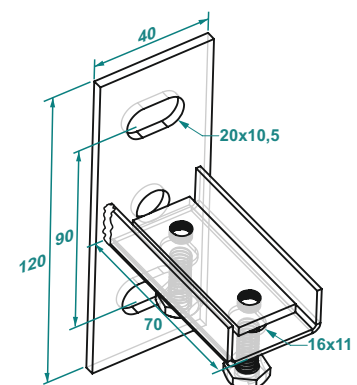

MATERIAL

EG: Electro-galvanised (8-12 Micron) EN ISO 2081

Available finishes:

Steel, strip-galv. acc. to TS-EN ISO 1461:2011 (HDG)

Thickn. (ga) [mm]: 4.0

38/40 C Rail Head Plate

"C" плоча на главата на релсата (38/40)

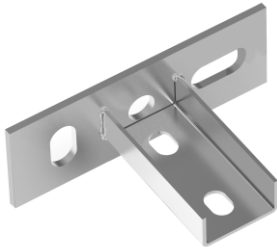

*Used with CL channels 38x40, 40x60, 41x41

Electro-Galvanized

UT5		EG					
CODE	CHANNEL SUPPORT		BASE PLATE	LENGTH	LOAD Fz	kg	pcs
	Description	mm					
UT5 01 EG	Crosswise	38/40	140x50x6	90	1,00	0,630	25

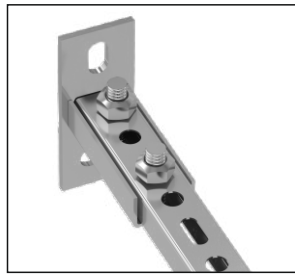

*Used with CL channels 38x40, 40x60, 41x41 * Pre-assembled with double rail nut

Electro-Galvanized

UT5		EG					
CODE	CHANNEL SUPPORT		BASE PLATE	LENGTH	LOAD Fz	kg	pcs
	Description	mm					
UT5 02 EG	Lengthwise	38/40	140x50x6	90	1,00	0,630	25

38/40 C Rail Head Plate

"C" плоча на главата на релсата (38/40)



*Used with CL channels 38x40, 40x60, 41x41 * Pre-assembled with double rail nut

Electro-Galvanized

UT5		EG						
CODE	CHANNEL SUPPORT		BASE PLATE	LENGTH	DOUBLE RAIL NUT		kg	pcs
	Description	mm			Size	Bolt		
UT5 11 EG	Crosswise	38/40	140x50x6	90	33x80x4	M10x20	0,760	25

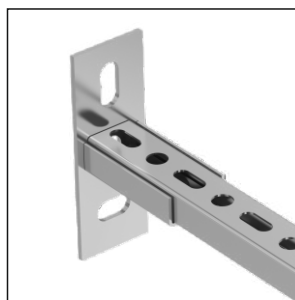

UT5		EG						
CODE	CHANNEL SUPPORT		BASE PLATE	LENGTH	DOUBLE RAIL NUT		kg	pcs
	Description	mm			Size	Bolt		
UT5 12 EG	Lengthwise	38/40	140x50x6	90	33x80x4	M10x20	0,760	25

UT5 01 EG
Crosswise Model

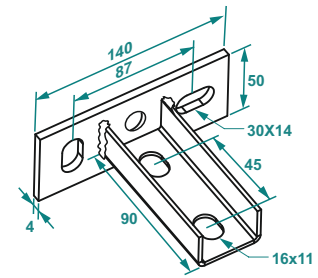

UT5 02 EG
Lengthwise Model

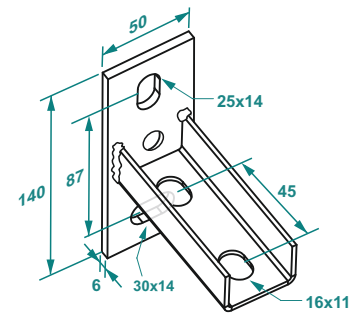

UT5 11 EG
Crosswise Model

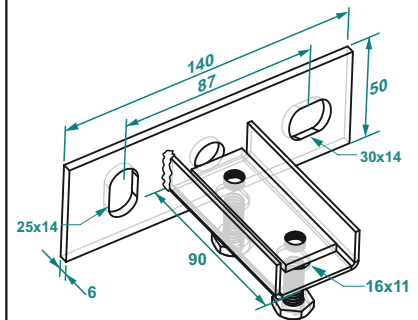

UT5 12 EG
Lengthwise Model

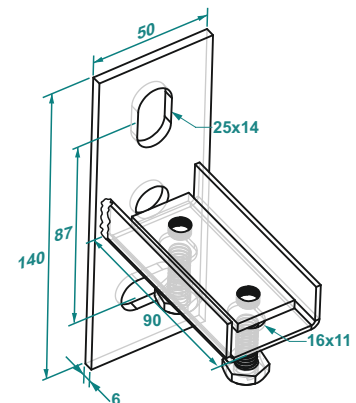

MATERIAL

EG: Electro-galvanised (8-12 Micron) EN ISO 2081

Available finishes:

Steel, strip-galv. acc. to TS-EN ISO 1461:2011 (HDG)

Thickn. (ga) [mm]: 4.0

C Rail Head Plate

"C" плоча на главата на релсата

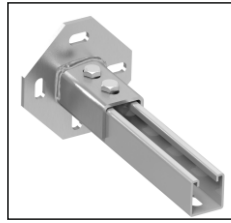

Electro-Galvanized

UT6		EG									
CODE	CHANNEL	ARM SIZE				BASE PLATE SIZES				kg 1 pc	pcs
	mm	G,mm	L,mm	T,mm	A=B,mm	S,mm	C,mm	D=F,mm			
UT6 21 EG	21x41	19	95	4,0	135	6,0	13x25	95	0,77	10	
UT6 41 EG	41x41	39	95	4,0	135	6,0	13x25	95	0,88	10	
UT6 62 EG	62x41	60	130	4,0	170	6,0	13x25	130	1,45	5	
UT6 82 EG	82x41	80	130	4,0	210	6,0	13x25	170	2,04	5	

C Rail Head Plate

"C" плоча на главата на релсата

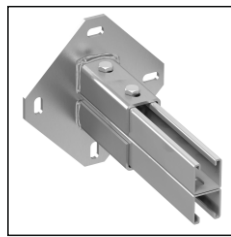

Electro-Galvanized

UT7		EG									
CODE	CHANNEL	ARM SIZE				BASE PLATE SIZES				kg 1 pc	pcs
	mm	G,mm	L,mm	T,mm	A=B,mm	S,mm	C,mm	D=F,mm			
UT7 21D EG	21x41	44	130	4,0	135	6,0	13x25	95	1,14	10	
UT7 41D EG	41x41	85	130	4,0	210	6,0	13x25	170	2,16	5	
UT7 62D EG	62x41	126	130	4,0	255	6,0	13x25	215	2,68	2	
UT7 82D EG	82x41	166	195	5,0	255	6,0	13x25	215	3,47	2	

C Rail Head Plate

"C" плоча на главата на релсата

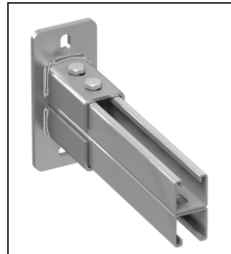

Electro-Galvanized

UT8		EG									
CODE	CHANNEL	ARM SIZE				BASE PLATE SIZES				kg 1 pc	pcs
	mm	G,mm	L,mm	T,mm	Size (AXB)	S,mm	C,mm	D,mm			
UT8 41D EG	83x41	84	95	4,0	180x80	8,0	13x20	140	1,51	10	

C Rail Head Plate

"C" плоча на главата на релсата



Electro-Galvanized

UT8		EG									
CODE	CHANNEL	ARM SIZE				BASE PLATE SIZES				kg 1 pc	pcs
	mm	G,mm	L,mm	T,mm	Size (AXB)	S,mm	C,mm	D,mm			
UT8 62D EG	124x41	126	95	4,0	220x90	8,0	13x20	180	1,85	10	

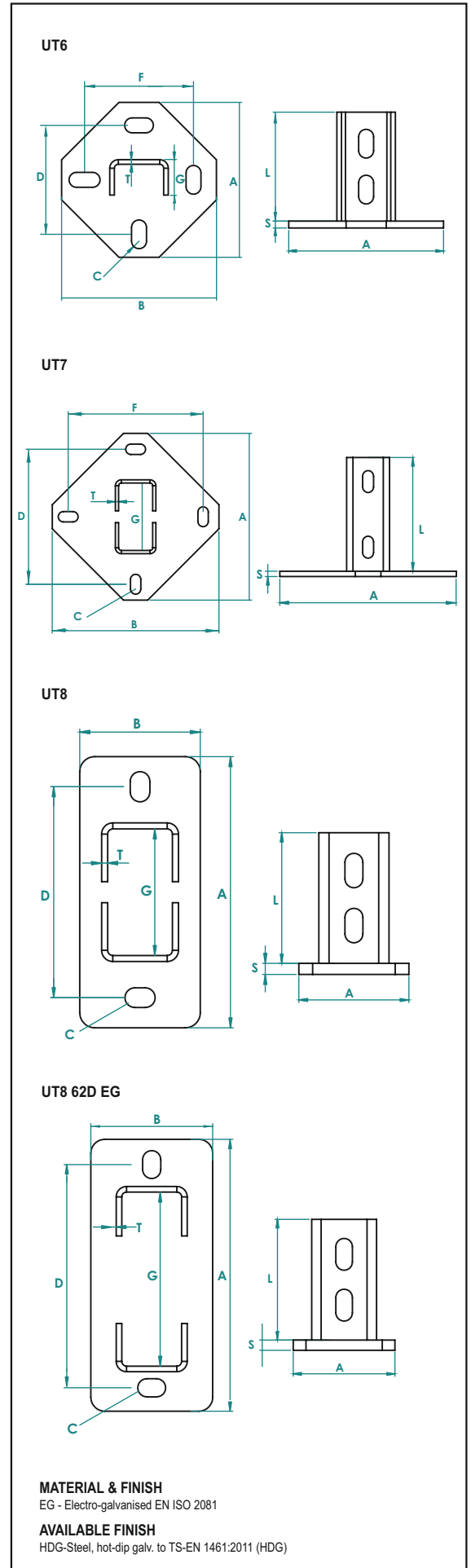

MATERIAL & FINISH
EG - Electro-galvanized EN ISO 2081

AVAILABLE FINISH
HDG-Steel, hot-dip galv. to TS-EN 1461:2011 (HDG)

CL Channel Vertical Support

Вертикална поддръжка на канал "CL"

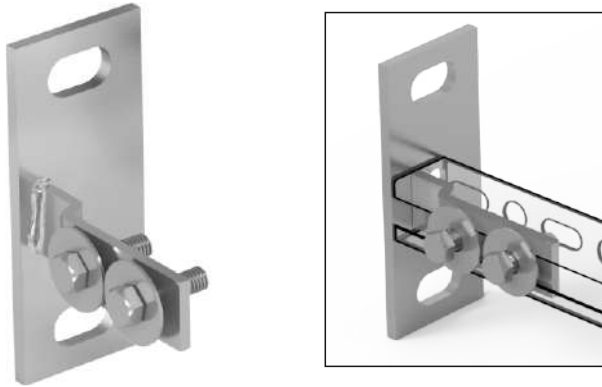

Electro-Galvanized

CDV							EG		
CODE	Width mm	Base mm	Thickness T,mm	Length L,mm	Load FZ kN	Load F kN	1 pc		
CDV 40 EG	30	120x40	4,0	82,5	0,80	1,50	0,270	100	
CDV 28 EG	24	120x40	4,0	82,5	0,80	1,50	0,230	100	

CL Channel Horizontal Support

Хоризонтална опора на канала "CL"

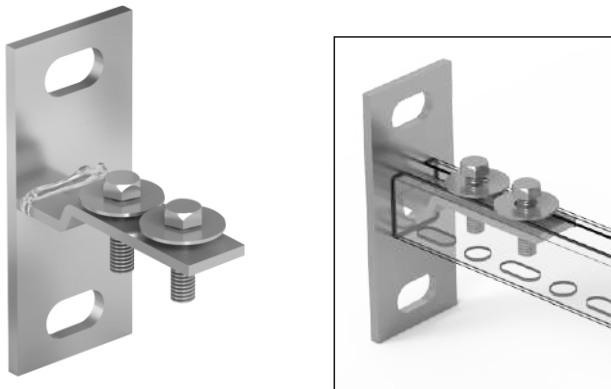

Electro-Galvanized

CDH							EG		
CODE	Width mm	Base mm	Thickness T,mm	Length L,mm	Load FZ kN	Load F kN	1 pc		
CDH 40 EG	40	120x40	4,0	82,5	0,80	1,50	0,270	100	
CDH 28 EG	24	120x40	4,0	82,5	0,80	1,50	0,230	100	

CDV

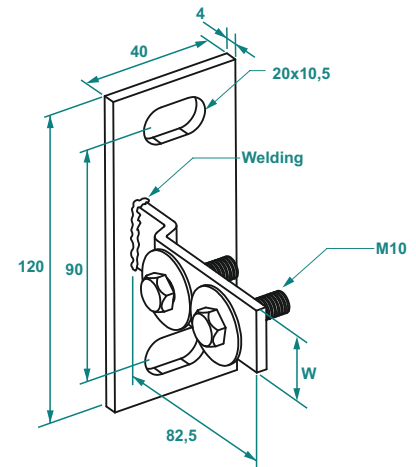

CDH

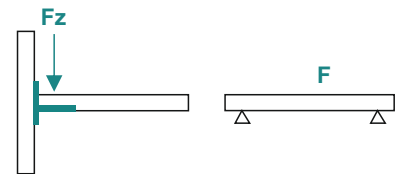
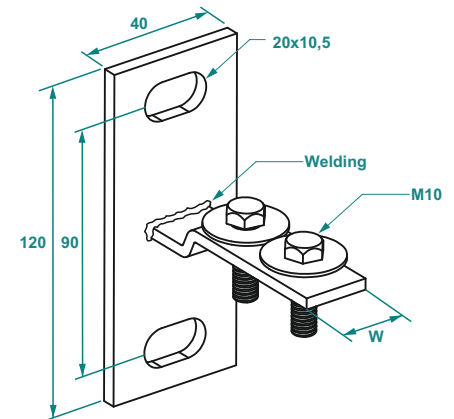

MATERIAL & FINISH

EG - Electro-galvanised EN ISO 2081

AVAILABLE FINISH

HDG-Steel, Hot-dip galv. to TS-EN ISO 1461:2011 (HDG)

C Channel Adjustable Brace Fitting Base

"C" канал регулируема основа за монтаж на скоби

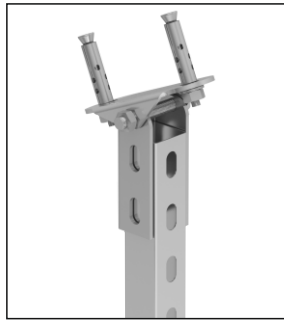
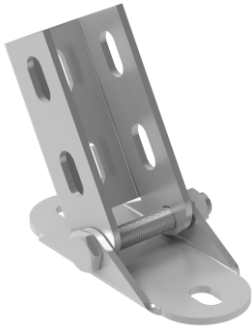

Electro-Galvanized

CDB - 23A		EG					
CODE	CHANNEL SUPPORT	BASE PLATE	LENGTH	BOLT			
	Description	mm	mm	L,mm			Metric
CDB-23A EG	Adjustable	41x41	150x50x4	120	M12x70	1,120	10

U Bolt Connection Plate

Свързваща плоча на U-болт



Electro-Galvanized

UBD		EG					
CODE	Hole		Width	Length	Thickness		
	d1, mm	d2, mm	mm	L,mm	T,mm		
UBD 13 EG	11	13	30	80	4,0	0,090	100
UBD 17 EG	11	17	30	80	4,0	0,090	100

CL Channel 90° Angle Fittings

90° ъгли фитинги на канал "CL"

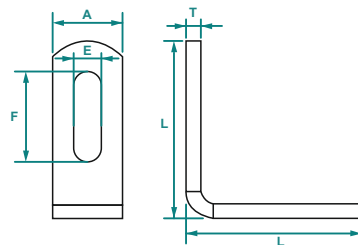

Electro-Galvanized

CLB 11		EG					
CODE	Channel Support	Size	Length	FxE			
	Description	mm	AxT, mm	L, mm			
CLB 11 EG	90°	27/28	28x5	69	10,5X35	0,110	100
CLB 12 EG	90°	38/40	40X6	86	13x40	0,230	100

CL Channel 45° Angle Fittings

45° ъгли фитинги на канал "CL"

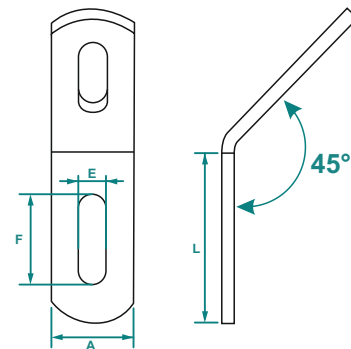

Electro-Galvanized

CLB 21		EG					
CODE	Channel Support	Size	Length	FxE			
	Description	mm	AxT, mm	L, mm			
CLB 21 EG	45°	27/28	28x5	69	10,5X35	0,110	100
CLB 22 EG	45°	38/40	40X6	86	13x40	0,230	100

CDB-23A

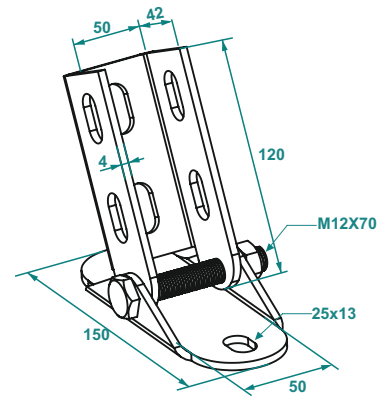

UBD

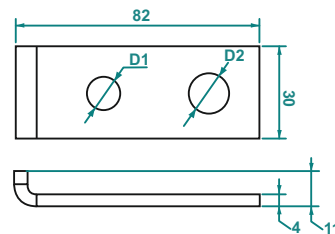

CLB 11 / CLB 12

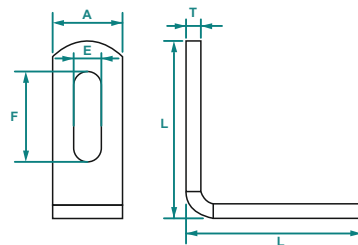

CLB 21 / CLB 22

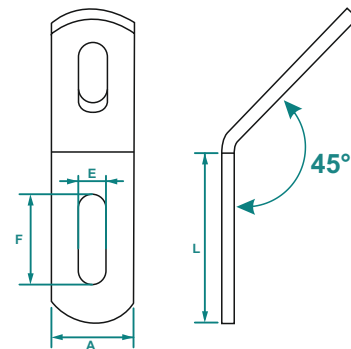

MATERIAL & FINISH

EG - Electro-galvanised EN ISO 2081

Rail Connection

Профилен конектор



Electro-Galvanized

CLE		EG			
CODE	SIZE	LENGTH	BOLT	kg	pcs
	B, mm	L, mm	metric	1 pc	
CLE 40 EG	40	160	M8x20	0,450	25
CLE 28 EG	28	160	M8x15	0,250	50

C Channel U Fittings

U монтаж на "C" профил

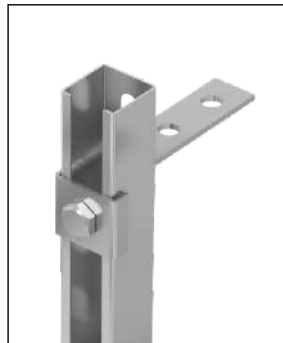
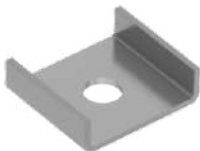

Electro-Galvanized

CYBU		EG			
CODE	SIZE	AxB	THICKNESS	kg	pcs
	D, mm	mm	T,mm	1 pc	
CYBU-01 EG	14	40x46	2,5	0,048	100
CYBU-01A EG	11	40x46	2,5	0,048	100
CYBU-01B EG	9	40x46	2,5	0,048	100

C Channel Angle Fittings 38/41

Ъглов обков от "C" профил



Electro-Galvanized

CLB 01		EG			
CODE	HOLE	AxB	THICKNESS	kg	pcs
	mm	mm	T,mm	1 pc	
CLB 01 EG	11x20	40x40	4,0	0,100	100

CLE

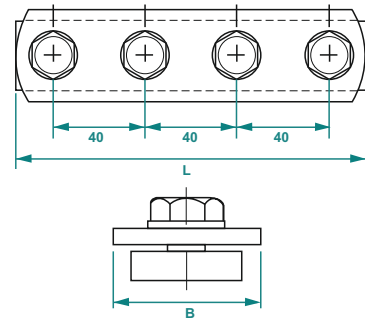

CYBU

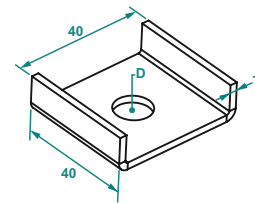

CLB 01

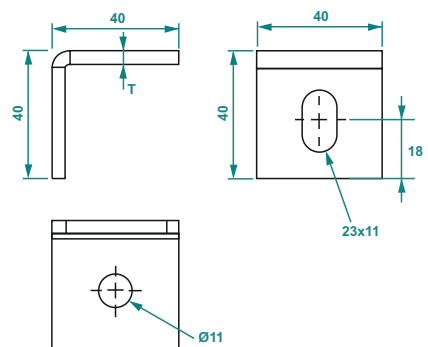

MATERIAL & FINISH

EG - Electro-galvanised EN ISO 2081

AVAILABLE FINISH

HDG-Steel, Hot-dip galv. to TS-EN ISO 1461:2011 (HDG)

C Channel Flat Fitting

"C" профил плосък обков

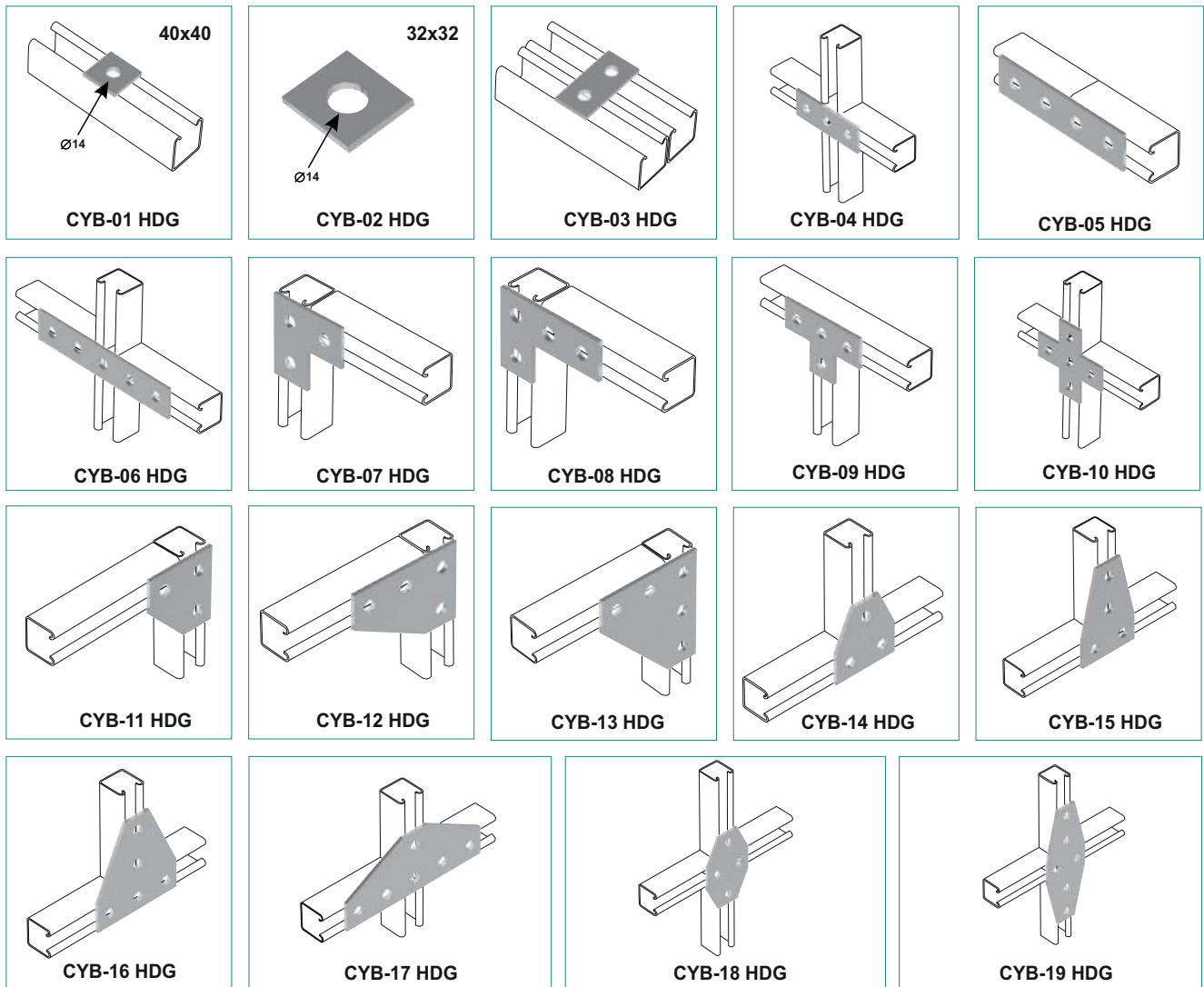

C Channel Angle Fitting

"C" Профилен ъглов обков

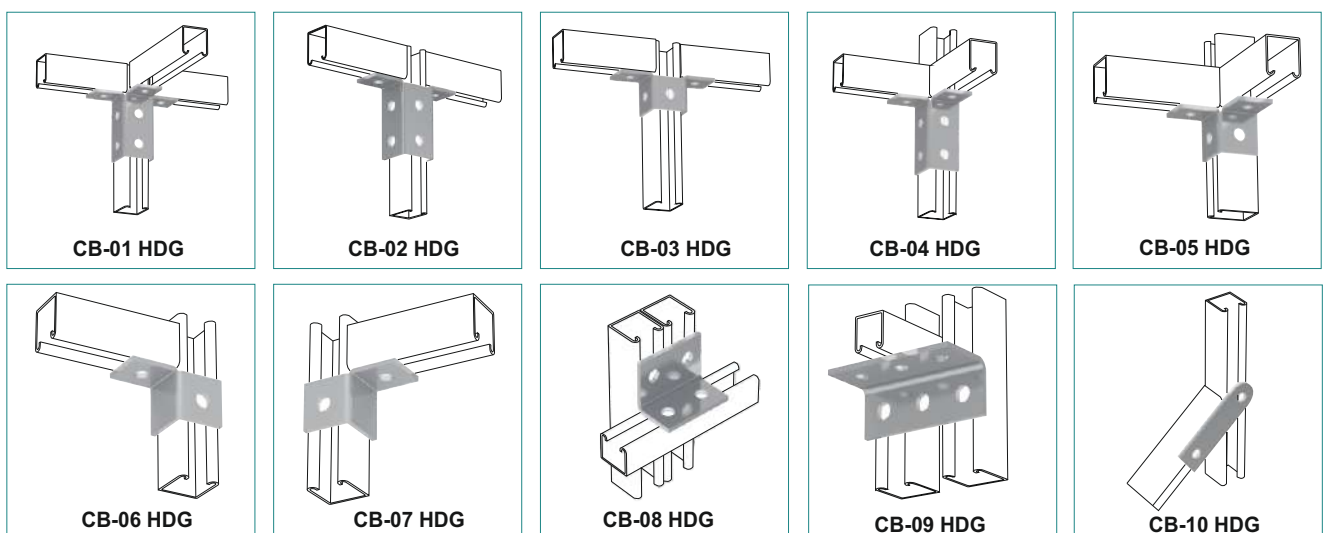

C Channel Corner Fittings

Ъглови фитинги "С" профил.

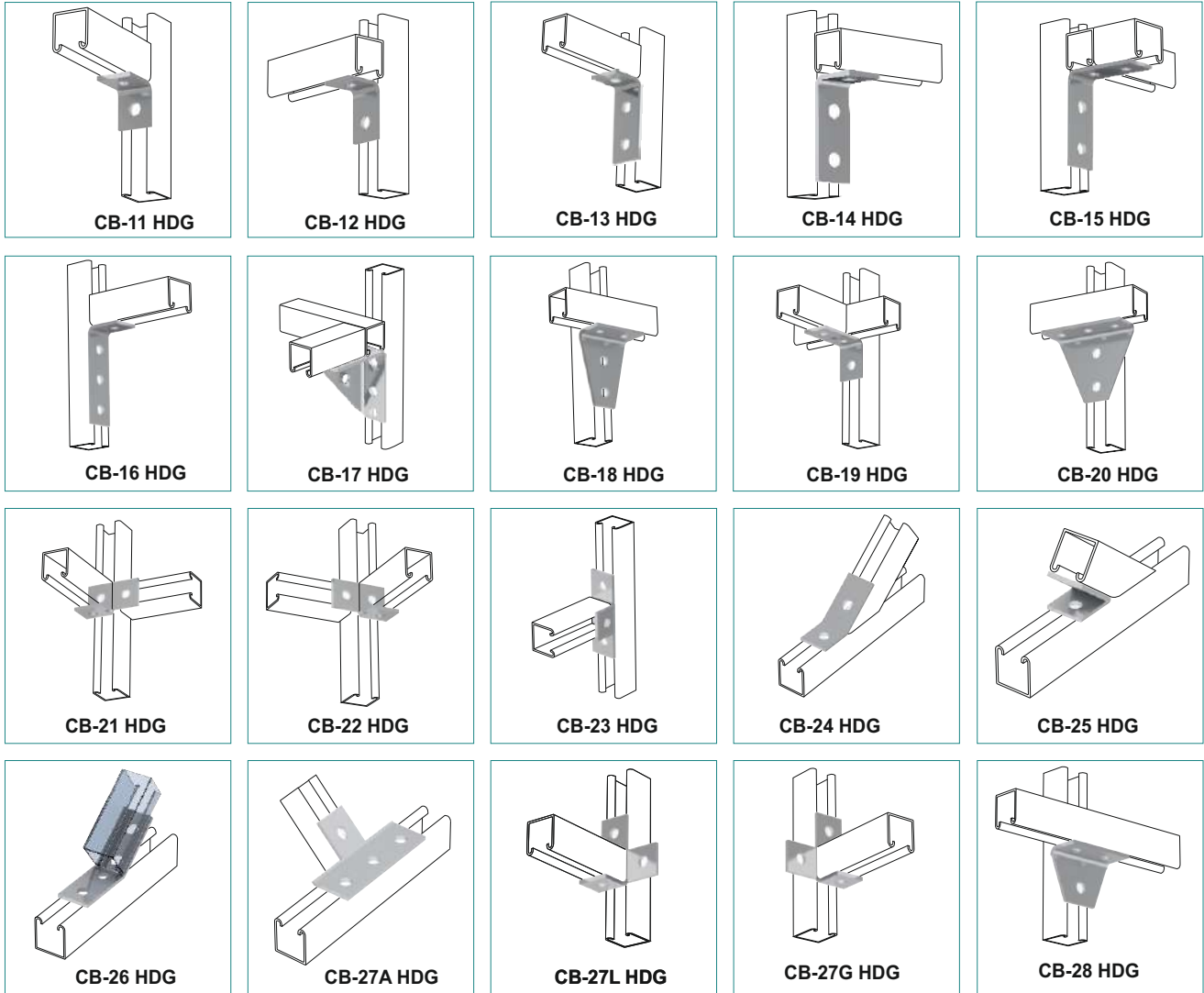

C Channel U and Z Fitting

U и Z фитинги на "С" профил

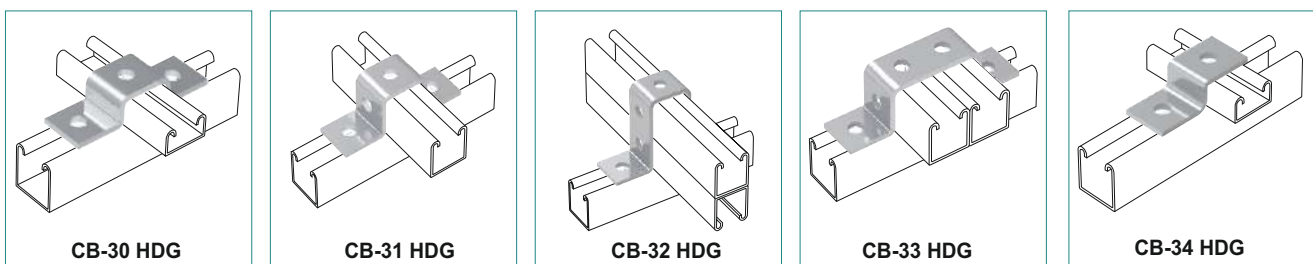

C Channel U and Z Fitting

U и Z обков от "С" профил

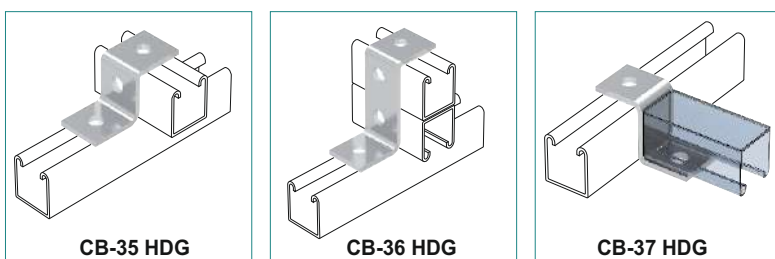

C Channel U Fitting (Clevis)

C Profil U Bağlantı Elemanı (Clevis) - U крепеж к С профилю



Support Hanger Clamp (Casting)

МЕТАЛНА СКОБА "C"



Die Cast (Кастинг)

PAM										
CODE	Hole D mm	A mm	C mm	E mm	N mm	M mm	Safe Working Load kN	kg 1 pc	pcs	
PAM-1	Ø9	20	36	38	18	M8x40	1,10	0,095	50	
PAM-2	Ø11	32	46	50	22	M10x40	2,40	0,190	50	
PAM-3	Ø13	35	72	58	40	M10x45	3,10	0,300	20	

PAM

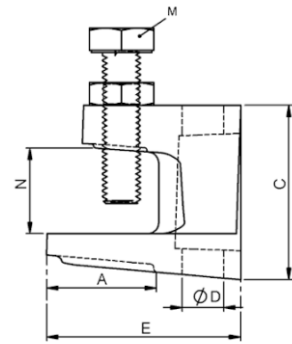

MATERIAL & FINISH

Die Cast

Head Plate With Combi Nut

Челна плоча с комбинирана гайка



SZP		EG			
CODE	Thread D Metric	Base Size mm	Plate Thickness T mm	kg 1 pc	pcs
SZP-9-EG	M8 / M10	70x18	2,5	0,032	100

SZP-9

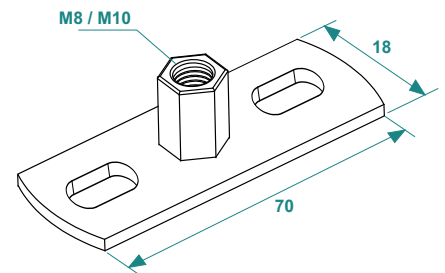

MATERIAL & FINISH

PG - Electro-galvanised EN ISO 2081

G-Clips / Ventilation Clamp

Г-щипки / Вентилационна скоба

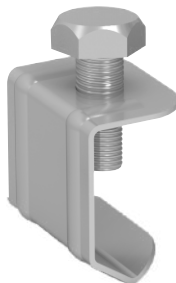

GK		EG			
CODE	Bolt mm	Thickness T mm	kg 1 pc	pcs	
GK M8	M8x20	2	0,030	100	

GK

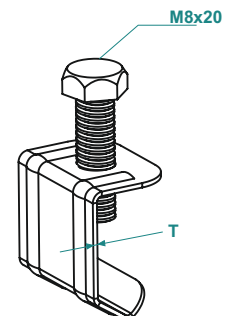

MATERIAL & FINISH

PG - Sendzimir Method to TS-EN 10346:2012

Triphone Adapter Screw

Трифонен адаптерен винт



Electro-Galvanized

TRFA	EG				
CODE	Size Metric mm	Length L mm	Head mm	KG 1 pc	pcs
TRFA M8 50	M8	50	torx head	0,012	100
TRFA M8 60	M8	60	torx head	0,014	100
TRFA M8 80	M8	80	torx head	0,019	100
TRFA M8 100	M8	100	torx head	0,024	100
TRFA M8 120	M8	120	torx head	0,029	100
TRFA M8 140	M8	140	flat Head	0,034	100
TRFA M8 150	M8	150	flat Head	0,036	100
TRFA M8 160	M8	160	flat Head	0,039	100
TRFA M8 180	M8	180	flat Head	0,043	100
TRFA M8 200	M8	200	flat Head	0,048	100
TRFA M8 220	M8	220	flat Head	0,053	100

Electro-Galvanized

TRFA	EG				
CODE	Size Metric mm	Length L mm	Head mm	KG 1 pc	pcs
TRFA M10 80	M10	80	torx head	0,031	100
TRFA M10 100	M10	100	torx head	0,038	100
TRFA M10 120	M10	120	torx head	0,046	100
TRFA M10 150	M10	150	flat head	0,057	100
TRFA M10 200	M10	200	flat head	0,076	100
TRFA M12 80	M12	80	flat head	0,045	100
TRFA M12 100	M12	100	flat head	0,056	100
TRFA M12 120	M12	120	flat head	0,067	100

TRFA

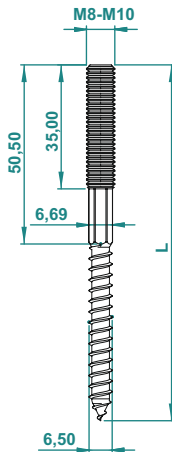

C Channel Fixing Bolt

Фиксиращ болт на "C" профил

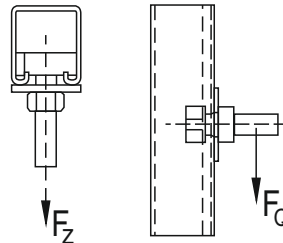
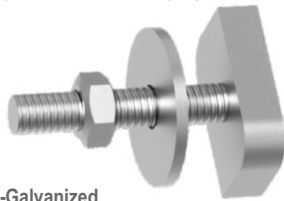

Electro-Galvanized

CODE	NTC		Load FZ kN	KG 1 pc	pcs
	Thread M,mm	Length L,mm			
NTC 4M8	M8	40	4,5	0,086	50
NTC 5M8	M8	50	4,5	0,089	50
NTC 6M8	M8	60	4,5	0,092	50
NTC 8M8	M8	80	4,5	0,095	50
NTC 10M8	M8	100	4,5	0,101	50
NTC 4M10	M10	40	5,0	0,102	50
NTC 5M10	M10	50	5,0	0,106	50
NTC 6M10	M10	60	5,0	0,111	50
NTC 8M10	M10	80	5,0	0,116	25
NTC 10M10	M10	100	5,0	0,125	25
NTC 4M12	M12	40	5,0	0,118	50
NTC 5M12	M12	50	5,0	0,125	50
NTC 6M12	M12	60	5,0	0,132	50
NTC 8M12	M12	80	5,0	0,139	25
NTC 10M12	M12	100	5,0	0,154	25

Loading Information of Fixing Bolts

Material Thickness [mm]	Connecting Thread	Max. Recommended Tensile Load [N]	Max. Recommended Transverse load Fq [N]
2.0	30	4,500	2,000
	40		
	50		
	60		
	80		
2.5	100	5,000	3,000
	125		
	150		

NTC

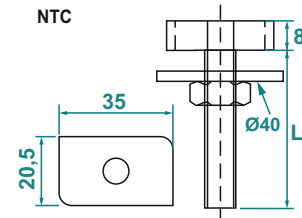

*Used with single C channels 21x41, 41X41, 62X41 and double C channels 42x41, 83x41, 124x41

CL Channel Fixing Bolts 38/40

Фиксиращ болт на "CL" профил (38/40)

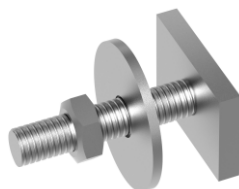

CL Channel Fixing Bolts 27/28

Фиксиращ болт на "CL" профил (27/28)



Electro-Galvanized

CODE	NTP		Load FZ kN	KG 1 pc	pcs
	Size Metric	Length L,mm			
NTP 3M10	M10	30	4,8	0,044	100
NTP 4M10	M10	40	4,8	0,048	100
NTP 5M10	M10	50	4,8	0,053	100
NTP 6M10	M10	60	4,8	0,058	100
NTP 8M10	M10	80	4,8	0,068	100
NTP 10M10	M10	100	4,8	0,077	100

Electro-Galvanized

CODE	NTN		Load FZ kN	KG 1 pc	pcs
	Size Metric	Length L,mm			
NTN 3M8	M8	30	1,7	0,022	100
NTN 4M8	M8	40	1,7	0,025	100
NTN 5M8	M8	50	1,7	0,028	100
NTN 6M8	M8	60	1,7	0,031	100
NTN 8M8	M8	80	1,7	0,037	100
NTN 10M8	M8	100	1,7	0,043	100

NTP

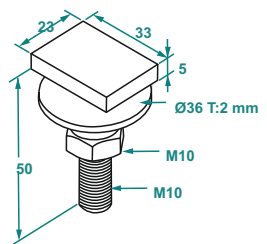

*Used with CL channels 38x40, 40x60

NTN

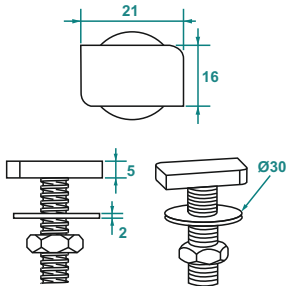

*Used with CL channels 27x18, 28x30

MATERIAL & FINISH
EG-Electro-galvanized EN ISO 2081

C Chaneel Spring Nuts

Пружинна гайка

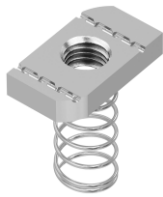

Electro-Galvanized

NYS	EG				
	CODE	HOLE Metric	SPRING L,mm	kg 1 pc	pcs
NYS 3M6	M6	35	0,041	100	
NYS 3M8	M8	35	0,041	100	
NYS 3M10	M10	35	0,041	100	
NYS 3M12	M12	35	0,041	100	

38/40 CL Rail Flat Fittings

Профилна квадратна гайка (38/40)

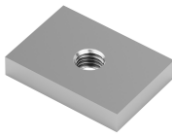

Electro-Galvanized

NP	EG				kg 1 pc	pcs
	CODE	Thread M,mm	AxB mm	Thickness T,mm		
NP M6 EG	M6	33x23	5,0	0,029	100	
NP M8 EG	M8	33x23	5,0	0,028	100	
NP M10 EG	M10	33x23	5,0	0,027	100	
NP M12 EG	M12	33x23	5,0	0,025	100	

27/40 CL Rail Flat Fittings

Профилна квадратна гайка (27/40)

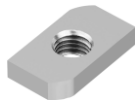

Electro-Galvanized

NN	EG				kg 1 pc	pcs
	CODE	Thread M,mm	AxB mm	Thickness T,mm		
NN M6 EG	M6	21x16	4,0	0,012	100	
NN M8 EG	M8	21x16	4,0	0,011	100	
NN M10 EG	M10	21x16	4,0	0,010	100	

Wide Flat (Plain) Washers

Широки плоски шайби



Electro-Galvanized

GP	EG				kg 1 pc	pcs
	CODE	Thread M,mm	D mm	Thickness T,mm		
GP M8 36 EG	M8	36	2,0	0,012	100	
GP M10 36 EG	M10	36	2,0	0,011	100	
GP M12 36 EG	M12	36	2,0	0,010	100	



Electro-Galvanized

GPC	EG				kg 1 pc	pcs
	CODE	Size Metric	D mm	Thickness T,mm		
GPC M8 40 EG	M8	40	3,0	0,028	100	
GPC M10 40 EG	M10	40	3,0	0,027	100	
GPC M12 40 EG	M12	40	3,0	0,026	100	
GPC M16 40 EG	M16	40	3,0	0,024	100	

Fixing Nut (Without Spring)

Фиксираща гайка (без пружина)



Electro-Galvanized

NS	EG				
	CODE	HOLE Metric	AXB mm	kg 1 pc	pcs
NS M6	M6	35x18	0,038	100	
NS M8	M8	35x18	0,038	100	
NS M10	M10	35x18	0,038	100	
NS M12	M12	35x18	0,038	100	

NYS

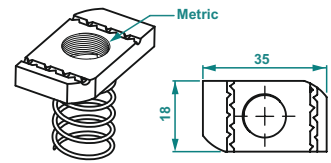

NS

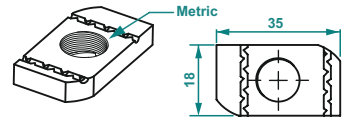

*Used with single C channels 21x41, 41x41, 62x41 and double C channels 42x41, 83x41, 124x41

NP

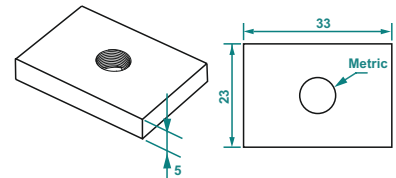

*Used with single CL channels 38x40, 40x60

NN

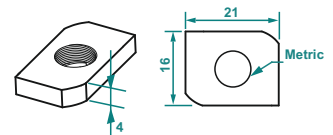

*Used with single CL channels 27x18, 28x30

GP

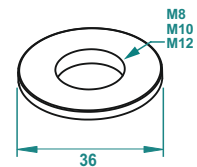

GPC

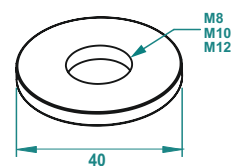

MATERIAL & FINISH

EG-Electro-galvanised EN ISO 2081

DIN 6923 Flanged Nut

Гайка с фланец DIN 6923



Electro - Galvanised

FS M		EG	
CODE	Thread Metric	1 pc	
FS M6 EG	M6	0,003	100
FS M8 EG	M8	0,006	100
FS M10 EG	M10	0,014	100
FS M12 EG	M12	0,030	100

DIN 934 Hex Nut

DIN 934 Шестостенна гайка



Electro - Galvanised

S M		EG	
CODE	Thread Metric	1 pc	
S M6 EG	M6	0,0025	500
S M8 EG	M8	0,0052	500
S M10 EG	M10	0,0116	500
S M12 EG	M12	0,0173	500

Electro - Galvanised

S M		EG	
CODE	Thread Metric	1 pc	
S M16 EG	M16	0,0333	50
S M18 EG	M18	0,0494	50
S M20 EG	M20	0,0644	50
S M24 EG	M24	0,1100	50

DIN 127 Spring Lock Washers

DIN 127 Пружинни шайби



Electro - Galvanised

YP M		EG	
CODE	Thread Metric	1 pc	
YP M6 EG	M6	0,001	500
YP M8 EG	M8	0,002	500
YP M10 EG	M10	0,004	500
YP M12 EG	M12	0,008	500

DIN 9021 Wide Flat (plain) washers

DIN 9021 Широки плоски (обикновени) шайби

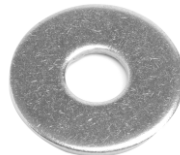

Electro - Galvanised

GP M		EG	
CODE	Thread Metric	D mm	1 pc
GP M6 EG	M6	18	0,003
GP M8 EG	M8	24	0,006
GP M10 EG	M10	30	0,012
GP M12 EG	M12	37	0,022

DIN 125 Flat Washer

DIN 125 Плоска шайба



Electro - Galvanised

P M		EG	
CODE	Thread Metric	D mm	1 pc
P M6 EG	M6	12	0,001
P M8 EG	M8	16	0,002
P M10 EG	M10	20	0,004
P M12 EG	M12	24	0,006

P M		EG	
CODE	Thread Metric	D mm	1 pc
P M16 EG	M16	30	0,011
P M18 EG	M18	34	0,015
P M20 EG	M20	37	0,017
P M24 EG	M24	44	0,028

FS M

Ø M6 / M8 / M10 / M12

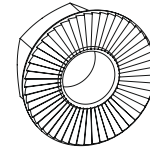
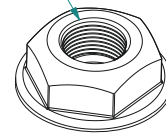

S M

Ø M6 / M8 / M10 / M12

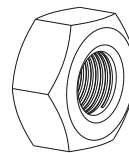
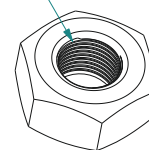

YP M

Ø M6 / M8 / 10 / 12

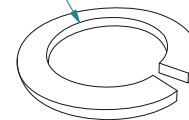

GP M

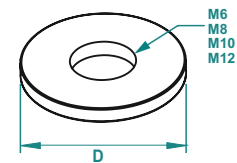

P M

Ø M6 / M8 / M10 / M12

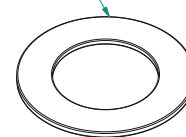

MATERIAL & FINISH

EG- Electro - Galvanised EN ISO 2081

DIN 933 Hex Bolt

Шестостенен болт DIN 933



Electro - Galvanised

AC M	M6	EG		
CODE	Thread Metric	Length L mm	kg 1 pc	pcs
AC M6 20 EG	M6	20	0,006	250
AC M6 25 EG	M6	25	0,007	250
AC M6 30 EG	M6	30	0,008	200
AC M6 35 EG	M6	35	0,009	200
AC M6 40 EG	M6	40	0,010	200
AC M6 50 EG	M6	50	0,012	200

M8				
CODE	Thread Metric	Length L mm	kg 1 pc	pcs
AC M8 20 EG	M8	20	0,012	100
AC M8 25 EG	M8	25	0,013	100
AC M8 30 EG	M8	30	0,014	100
AC M8 35 EG	M8	35	0,016	100
AC M8 40 EG	M8	40	0,018	100
AC M8 50 EG	M8	50	0,021	100
AC M8 60 EG	M8	60	0,024	100
AC M8 70 EG	M8	70	0,027	100

M10				
CODE	Thread Metric	Length L mm	kg 1 pc	pcs
AC M10 20 EG	M10	20	0,020	100
AC M10 25 EG	M10	25	0,023	100
AC M10 30 EG	M10	30	0,025	100
AC M10 35 EG	M10	35	0,028	100
AC M10 40 EG	M10	40	0,033	100
AC M10 45 EG	M10	45	0,035	100
AC M10 50 EG	M10	50	0,038	100
AC M10 55 EG	M10	55	0,040	100
AC M10 60 EG	M10	60	0,043	100
AC M10 65 EG	M10	65	0,046	100
AC M10 70 EG	M10	70	0,048	100
AC M10 75 EG	M10	75	0,050	100
AC M10 80 EG	M10	80	0,053	100
AC M10 90 EG	M10	90	0,058	100
AC M10 100 EG	M10	100	0,063	100

AC M	M12	EG		
CODE	Thread Metric	Length L mm	kg 1 pc	pcs
AC M12 25 EG	M12	25	0,031	50
AC M12 30 EG	M12	30	0,035	50
AC M12 35 EG	M12	35	0,039	50
AC M12 40 EG	M12	40	0,043	50
AC M12 50 EG	M12	50	0,051	50
AC M12 60 EG	M12	60	0,060	50
AC M12 65 EG	M12	65	0,064	50
AC M12 70 EG	M12	70	0,068	50
AC M12 80 EG	M12	80	0,076	50
AC M12 90 EG	M12	90	0,084	50
AC M12 100 EG	M12	100	0,090	50

M16				
CODE	Thread Metric	Length L mm	kg 1 pc	pcs
AC M16 35 EG	M16	35	0,083	50
AC M16 40 EG	M16	40	0,090	50
AC M16 45 EG	M16	45	0,097	50
AC M16 50 EG	M16	50	0,103	25
AC M16 55 EG	M16	55	0,110	25
AC M16 60 EG	M16	60	0,117	25
AC M16 65 EG	M16	65	0,123	25
AC M16 70 EG	M16	70	0,130	25
AC M16 75 EG	M16	75	0,137	25
AC M16 80 EG	M16	80	0,144	25
AC M16 90 EG	M16	90	0,157	25
AC M16 100 EG	M16	100	0,170	20
AC M16 110 EG	M16	110	0,184	20
AC M16 120 EG	M16	120	0,197	20
AC M16 130 EG	M16	130	0,210	20
AC M16 150 EG	M16	150	0,237	20

M20				
CODE	Thread Metric	Length L mm	kg 1 pc	pcs
AC M20 50 EG	M20	50	0,176	50
AC M20 60 EG	M20	60	0,196	50
AC M20 70 EG	M20	70	0,217	50
AC M20 80 EG	M20	80	0,238	25
AC M20 100 EG	M20	100	0,279	25
AC M20 140 EG	M20	140	0,361	25

AC M

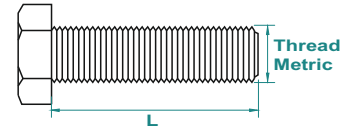
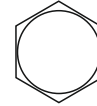

YSB M

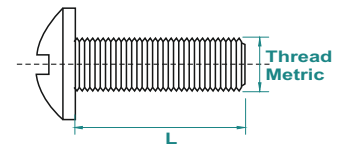
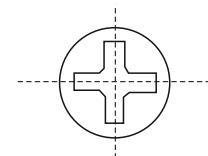

DIN 7985 Roofing Bolt

DIN 7985 Болт за покрив



Electro - Galvanised

YSB M	EG		
CODE	Thread Metric	Length L mm	kg 1 pc
YSB M6 15 EG	M6	15	0,005
YSB M6 20 EG	M6	20	0,006
YSB M6 25 EG	M6	25	0,007
YSB M6 40 EG	M6	40	0,010
YSB M8 15 EG	M8	15	0,008
YSB M8 20 EG	M8	20	0,011
YSB M8 25 EG	M8	25	0,013
YSB M8 40 EG	M8	40	0,020
YSB M8 50 EG	M8	50	0,025
YSB M8 60 EG	M8	60	0,030

YSB M	EG		
CODE	Thread Metric	Length L mm	kg 1 pc
YSB M10 25 EG	M10	25	0,027
YSB M10 30 EG	M10	30	0,030
YSB M10 40 EG	M10	40	0,035
YSB M10 50 EG	M10	50	0,040
YSB M10 60 EG	M10	60	0,046

MATERIAL & FINISH

EG- Electro - Galvanised EN ISO 10683

Drop in Anchor

Пускане на котва

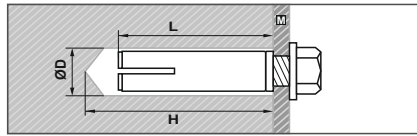

Electro - Galvanised

CD M		EG						
CODE	Thread Metric	Length L mm	Height H mm	Out Diameter D mm	Load kN	kg 1 pc	pcs	
CD M6	M6	20	20	7,4	1,0	0,006	100	
CD M8	M8	27	30	9,4	1,8	0,009	100	
CD M10	M10	40	40	11,6	3,6	0,016	50	
CD M12	M12	47	50	15,3	5,7	0,040	50	
CD M16	M16	65	65	20	7,4	0,100	50	

Draw in Anchor

Пускане на котва

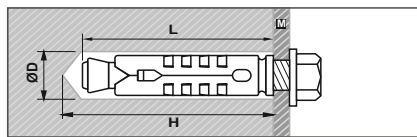

Electro - Galvanised

SD M		EG						
CODE	Thread Metric	Length L mm	Height H mm	Out Diameter D mm	Load kN	kg 1 pc	pcs	
SD M6	M6	45	50	10	0,75	0,010	100	
SD M8	M8	50	60	12,5	3,50	0,014	100	
SD M10	M10	55	65	15,5	5,00	0,023	50	
SD M12	M12	65	75	18,5	7,50	0,040	50	

Sleeve Anchor Pipe Type

Гилзов анкер (Тръбен тип)

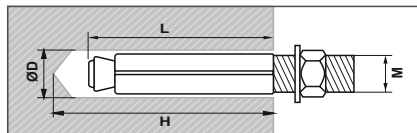

Electro - Galvanised

BD M		EG						
CODE	Thread Metric	Length L mm	Height H mm	Out Diameter D mm	Load kN	kg 1 pc	pcs	
BD M8 75	M8	75	80	10	9,00	0,036	100	
BD M10 85	M10	85	90	12	9,00	0,065	100	
BD M10 110	M10	110	120	12	11,00	0,086	110	
BD M12 90	M12	90	100	16	11,00	0,110	100	
BD M12 110	M12	110	120	16	11,00	0,135	100	
BD M16 120	M16	120	130	16	18,00	0,263	100	

Sleeve Anchor

Пускане на котва

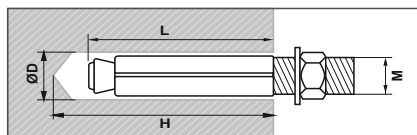

Electro - Galvanised

GD M		EG						
CODE	Thread Metric	Length L mm	Height H mm	Out Diameter D mm	Safe Tensile Load kN	Tightening Torque Nm	kg 1 pc	pcs
GD M6 45	M6	45	50	8	1,5	24	0,015	500
GD M8 55	M8	55	60	10	2,0	28	0,028	250
GD M8 75	M8	75	80	10	2,0	28	0,036	200
GD M10 70	M10	70	75	12	3,1	65	0,055	100
GD M10 85	M10	85	90	12	3,1	65	0,065	100
GD M10 110	M10	110	120	12	3,1	65	0,086	100
GD M12 90	M12	90	100	16	5,0	115	0,110	50
GD M12 110	M12	110	120	16	5,0	115	0,135	50

CD M

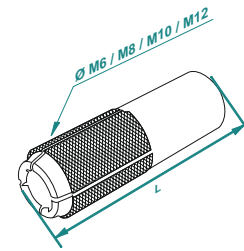

SD M

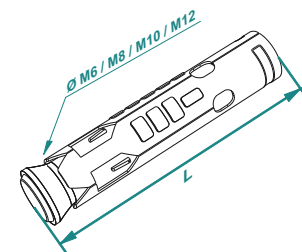

BD M

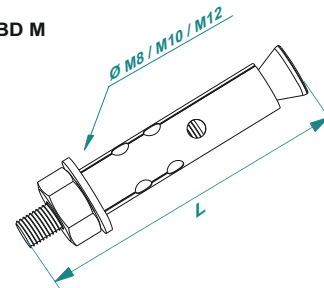

GD M

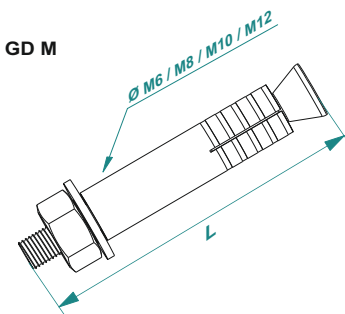

MATERIAL & FINISH

EG- Electro - Galvanised EN ISO 2081

Available Finishes:

SS- Stainless steel AISI 304L and AISI 316L (ss)

Wedge in Anchor

Пускане на котва

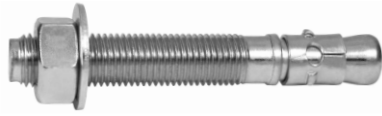

Electro - Galvanised

KD M						EG	
CODE	Thread Metric	Length L mm	Height H mm	Out Diameter D mm	Load kN	kg 1 pc	pcs
KD M6 45	M6	45	20	6	1,1	0,015	100
KD M8 75	M8	75	30	8	1,4	0,036	100
KD M10 90	M10	90	40	10	2,5	0,065	100
KD M10 110	M10	110	50	10	2,5	0,086	50
KD M12 110	M12	110	65	12	3,2	0,135	50
KD M16 145	M16	145	65	16	5,8	0,270	10

DIN7505 Screw

DIN 7505 Винт



Electro - Galvanised

VIDA				EG	
CODE	Thread Metric	Length L mm	Head Dk mm	kg 1 pc	pcs
VIDA M3.5 30 EG	M3.5	30	7	0,0013	500
VIDA M4 40 EG	M4	40	8	0,0022	500
VIDA M5 50 EG	M5	50	10	0,0039	500
VIDA M6 60 EG	M6	60	12	0,0075	500

Plastic Anchor

Пластмасова котва



Plastic

PDM					
CODE	Thread Metric	Length L mm	Out Diameter D mm	Gr 1 pc	pcs
PD M6	M6	28	6	0,0006	500
PD M8	M8	35	8	0,0008	500
PD M10	M10	45	10	0,0017	500
PD M12	M12	55	12	0,0034	500

C Channel Strip, Rubber

"C" Канална лента, гума

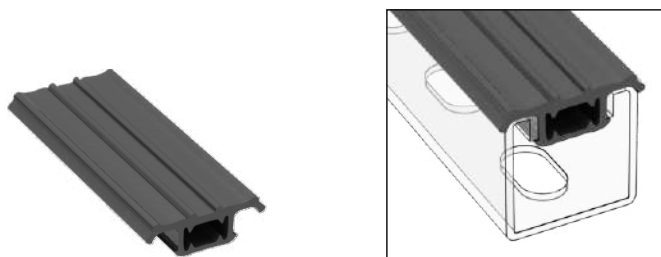

EPDM

FIT						
CODE	Material	Channel Size WxH mm			Gr 1 pc	pcs
FIT 41	EPDM	41X21	41X41	41X62	0,0006	500

KD M

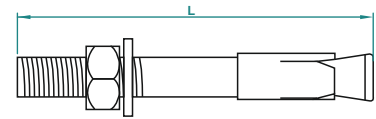

VIDA

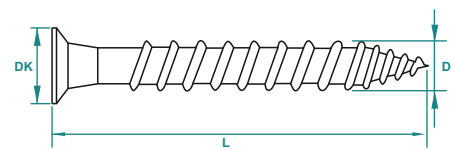

MATERIAL & FINISH

EG- Electro - Galvanised EN ISO 2081

PDM

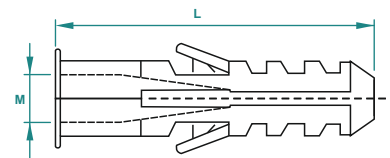

MATERIAL & FINISH

Plastic

FIT



Rubber Quality		EPDM, Color black Etilen-Probien-Dien-Caoutchouc
Hardness	Shore - A	45 / +5; -0
Temperature Resistance	°C	-40 / +120
Elongation at rupture	%	> 400
Tensile Strength	N / mm ²	> 6
Resilience	%	> 40

MATERIAL & FINISH

EPDM



ЕНЕРДЖИ ГРУП ООД

ЖК.СТУДЕНСКИ ГРАД УЛ.АКАД
ЙОРДАН ТРИФОНОВ 8
НИВО 2 ОФИС 21 ГР. СОФИЯ

+3590885498968
info@abenergygroup.bg
info@abelectric.bg

